

Gregory J. Manin Alicia Artusi Robert Quinn  
Alistair McCallum Claire Thacker Susan Banman Sileci



# engage

Special edition



Student Book & Workbook

Starter

OXFORD

Gregory J. Manin Alicia Artusi Helen Halliwell

# engage

Special edition



Student Book

Starter



# The structure of Engage

## Introducing the topic

### Vocabulary

- These pages give the objectives of the unit and are an illustrated presentation of the vocabulary related to the unit topic. They are followed by consolidation activities.



## Exploring the topic

### Reading

- The reading texts use a variety of different genres. The reading text is supported by activities which develop the ability to extract and interpret information, and encourage personalization.

### Grammar

- Grammar pages formally present a single point, or two related points, followed by practice activities. At the bottom of the page there is a personalization activity (Over to you!).



## Building the topic

### Vocabulary

- This introduces a new, related, set of words which are taught, modeled, and practiced.

### Grammar

- The second grammar page develops or expands on the grammar point of the unit. At the bottom of the page there is a personalization activity (Over to you!).

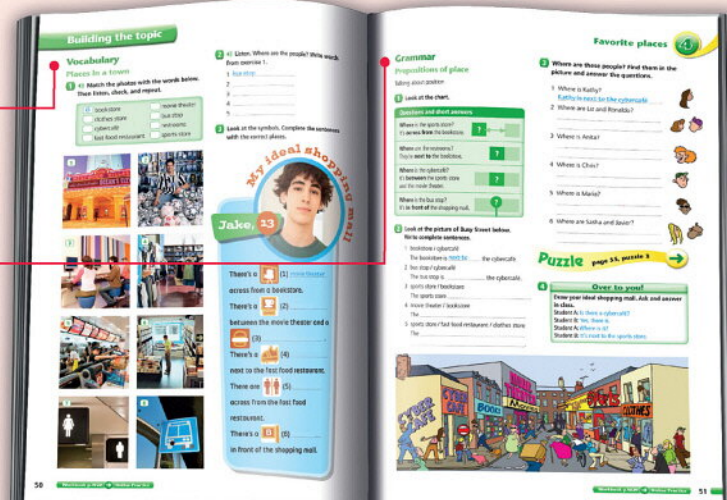

## Living English

### Reading

- The reading texts introduce a variety of different genres and are more extensive than those in Exploring the topic. The reading text is supported by activities which develop the ability to extract and interpret information and encourage personalization.

### Listening

- The listening activities follow on from the reading topic and are followed by practice activities.

### Speaking

- The speaking activities follow on from the listening activities. There are also pronunciation activities. Finally there is a personalization activity.





# The structure of Engage

## Round-up

### Writing

- Writing lessons are based around a model text and are the opportunity to put into practice everything learned in the unit.

### I can...

- This section provides an opportunity to review and reflect on progress through self-assessment.

### Puzzles

- The puzzles are a fun way of practicing and reinforcing skills learned in the unit.

## Review

- The review pages appear after every two units and consolidate the grammar and vocabulary of the unit.

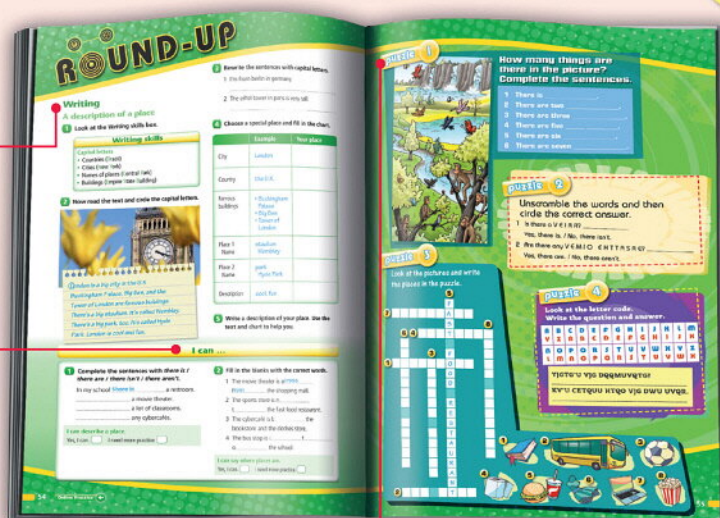

## Magazine

- The magazine pages appear after every two units. They focus on a topic which relates to or builds on the topic of the preceding units, and expand global awareness. They provide further opportunities for personalization, critical thinking, and project work.

## Workbook

- The Workbook, which follows the Student Book, provides one page of grammar reference, and four pages of additional practice activities, for each unit.



## Online Practice

- Extra grammar, vocabulary, and skills practice is available online, with automatic marking.

## Student website

- The website contains fun vocabulary and grammar practice, with instant feedback, and webquests with links to authentic websites.

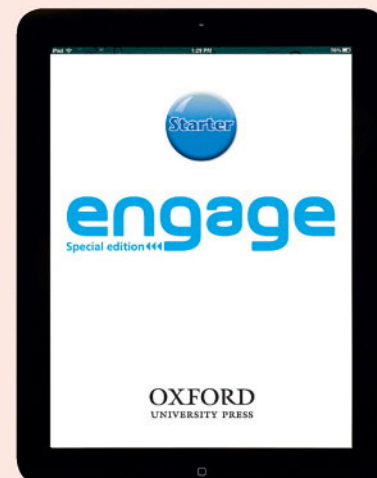



# Contents

		Grammar	Vocabulary
<b>Welcome</b> page 6			
<b>1</b>	<b>Identity</b> page 12	<i>be</i> (questions) <i>be</i> (affirmative)	Countries and nationalities Feelings
<b>2</b>	<b>My stuff</b> page 22	Possessive adjectives Possessive 's <i>this / that / these / those</i>	Describing objects Things in your bedroom
<b>Review A</b> page 32			
<b>Magazine A</b> page 34			
<b>3</b>	<b>Favorite people</b> page 36	<i>be</i> (negative) <i>be</i> (yes / no questions)	Jobs Family
<b>4</b>	<b>Favorite places</b> page 46	<i>there is / there are</i> Prepositions of place	Nature Places in a town
<b>Review B</b> page 56			
<b>Magazine B</b> page 58			
<b>5</b>	<b>Fun and games</b> page 60	<i>can</i> (ability) Imperatives	Sports activities Sports verbs
<b>6</b>	<b>Work and play</b> page 70	Simple present (affirmative) Simple present ( <i>he / she / it</i> )	Daily routines School subjects
<b>Review C</b> page 80			
<b>Magazine C</b> page 82			
<b>7</b>	<b>This is me</b> page 84	Simple present (negative) Simple present ( <i>yes / no</i> questions)	Preferences Clothes
<b>8</b>	<b>Free time</b> page 94	Simple present ( <i>Wh-</i> questions) Expressions of frequency	Going out Leisure activities
<b>Review D</b> page 104			
<b>Magazine D</b> page 106			
<b>Workbook</b> page W2			

Reading		Listening		Speaking		Round-up	
Teen talk Who are they? Reading skills: Scanning	Giving personal information	Making introductions Pronunciation: Contractions	Writing: A profile Writing skills: Subject pronouns Puzzles				
My favorite thing Objects from the past Reading skills: Using pictures	Describing your bedroom	Asking about possessions Pronunciation: <i>th</i> sounds	Writing: Favorite things Puzzles				
Who is your favorite person? Famous people quiz Reading skills: predicting	Talking about your family	Talking about people and their jobs Pronunciation: Intonation in questions	Writing: An email about your family Puzzles				
Iguaçu Falls Welcome to Los Angeles the city of angels	Describing your hometown	Asking for directions Pronunciation: <i>o</i> sounds	Writing: A description of a place Writing skills: Capital letters Puzzles				
International Singing Star Extreme sports	Describing someone's abilities	Talking about abilities Pronunciation: <i>can</i>	Writing: Describing friends' abilities Writing skills: <i>and</i> and <i>but</i> Puzzles				
Different countries, different lives An extraordinary teenager Reading skills: Predicting what a text is about	Describing your daily routine	Talking about school subjects Pronunciation: Simple present -s	Writing: An e-mail about your day Writing skills: <i>then</i> Puzzles				
All about me Graffiti slogans	Describing your favorite sports team	Talking about habits Pronunciation: <i>ea</i> sounds	Writing: My preferences Writing skills: <i>because</i> Puzzles				
Music Unlimited Free time around the world Reading skills: Using dictionaries	Asking about free time activities	Talking about frequency Pronunciation: Silent letters	Writing: My free time Writing skills: <i>too</i> Puzzles				



# Welcome

## OBJECTIVES

- the alphabet
- numbers 1-100
- time
- colors
- classroom objects
- subject pronouns

## Get started

1 Write your name.

First name:

Last name:

2 **Over to you!**

Write some English words you know.

Internet, hip-hop, ...

## Alphabet

3 Listen and repeat.



4 Listen and repeat.

/eɪ/	/i/	/ɛ/	/aɪ/	/oʊ/	/u/	/ɑː/
a	b	f	i	o	q	r
h	c	l	y		u	
j	d	m			w	
k	e	n				
	g	s				
	p	x				
	t					
	v					
	z					

5 Listen and repeat.

- a e i o u
- u a o i e
- o i e u a

6 Listen. Circle the letter you hear.

- A / E
- E / I
- G / J
- I / Y
- V / B
- P / B

7 **Over to you!**

Ask and answer in class.

How do you spell your first name?

How do you spell your last name?

## Numbers 0–20

- 1 Match the numbers with the words.  
Then listen and repeat.

0	<b>two</b>	<b>three</b>
1	<b>five</b>	
2		<b>sixteen</b>
3	<b>one</b>	
4		<b>fifteen</b>
5	<b>eleven</b>	
6	<b>twenty</b>	<b>four</b>
7	<b>nine</b>	
8		<b>seventeen</b>
9	<b>fourteen</b>	
10		<b>thirteen</b>
11	<b>six</b>	<b>seven</b>
12	<b>nineteen</b>	
13		<b>twelve</b>
14	<b>twelve</b>	
15		<b>eighteen</b>
16	<b>zero</b>	
17		<b>ten</b>
18	<b>ten</b>	<b>eight</b>
19		
20		

- 2 Listen and repeat the pairs of numbers.

• 1 11	• 4 14	• 7 17
• 2 12	• 5 15	• 8 18
• 3 13	• 6 16	• 9 19

- 3 Listen to the numbers. Write the next number in the sequence.

1 **five** ..... 3 .....

2 ..... 4 .....

- Now listen and check.

## Colors

- 4 Label the numbers with the words below.  
Then listen, check, and repeat.

black	blue	brown	green	orange
pink	purple	red	white	yellow

<b>4</b> <small>black</small> .....	<b>16</b> .....
<b>12</b> .....	<b>9</b> .....
<b>18</b> .....	<b>19</b> .....
<b>5</b> .....	<b>11</b> .....
<b>20</b> .....	<b>13</b> .....

- 5 Ask and answer about the numbers.

Student A: What color is sixteen?

Student B: It's pink.

- 6 **Over to you!**

Complete the sentence. Then tell the class.

My favorite color is .....



# Welcome

## Classroom objects

1 Label the objects with the words below. Then listen, check, and repeat.

eraser notebook pen pencil  
pencil case poster ruler school bag

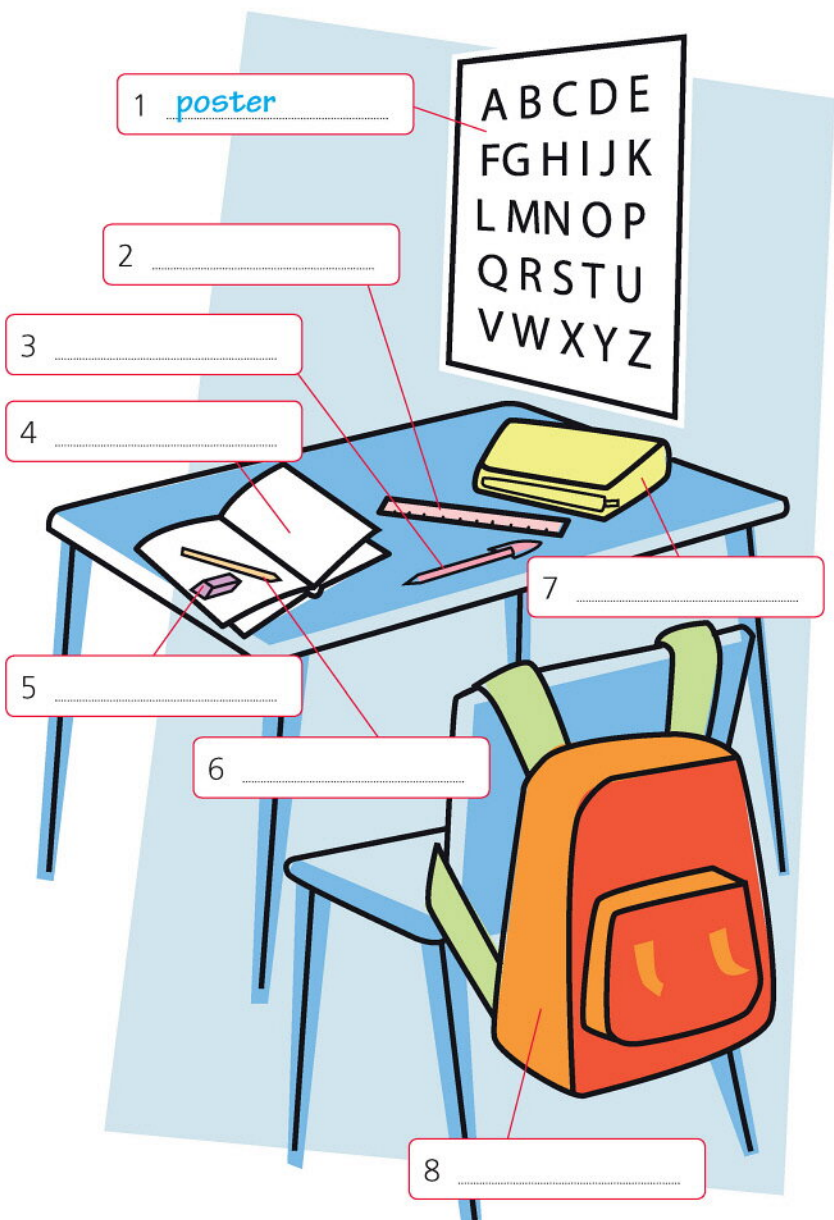

2 **Over to you!**

Ask and answer.

What is it? It's a pencil.

## Days of the week

3 Listen and repeat.

Monday Tuesday Wednesday Thursday  
Friday Saturday Sunday

4 Listen to the days. Write the missing day.

1 Wednesday 3 \_\_\_\_\_  
2 \_\_\_\_\_ 4 \_\_\_\_\_

Now listen and check.

5 **Over to you!**

Complete the sentence.  
Today is \_\_\_\_\_.

## Months of the year

6 Listen and repeat.

January February March April May  
June July August September October  
November December

7 **Over to you!**

Complete the sentence.  
My birthday is in \_\_\_\_\_.

Answer the teacher.  
Teacher: *When's your birthday?*  
Student: *In May.*

8 Complete the class birthday calendar.

**class birthday calendar**

January	February	March	April
May	June	July	August
September	October	November	December





## Animals

1 Label the animals with the words below. Then listen, check, and repeat.

bird cat dog fish hamster horse mouse snake



1 fish



2 \_\_\_\_\_



3 \_\_\_\_\_



4 \_\_\_\_\_



5 \_\_\_\_\_



6 \_\_\_\_\_



7 \_\_\_\_\_



8 \_\_\_\_\_

## 2 Over to you!

Ask and answer questions about your favorite animal.

Student A: *What's your favorite animal?*

Student B: *A horse.*

## Numbers 21–100

3 Match the numbers with the words. Then listen and repeat.

21	<b>thirty</b>	<b>ninety</b>
30	<b>seventy</b>	
32	<b>ninety-nine</b>	
40	<b>thirty-two</b>	
43	<b>sixty</b>	<b>forty</b>
50	<b>a hundred</b>	
54	<b>ninety-eight</b>	
60	<b>fifty</b>	
65	<b>sixty-five</b>	
70	<b>seventy-six</b>	
76	<b>forty-three</b>	
80	<b>eighty</b>	
87	<b>eighty-seven</b>	
90	<b>fifty-four</b>	
98	<b>twenty-one</b>	
99		
100		

4 Listen. Write the numbers you hear.

90  
 \_\_\_\_\_  
 \_\_\_\_\_

5 Write the number using words.

- The number of days in January.  
*thirty-one*
- The number of classrooms in your school.  
 \_\_\_\_\_
- The number of students in your class.  
 \_\_\_\_\_
- The number of boys in your class.  
 \_\_\_\_\_
- The number of girls in your class.  
 \_\_\_\_\_



# Welcome

## Telling the time

1) Label the clocks with the times below. Then listen, check, and repeat.

ten oh five   one forty-five   ~~nine o'clock~~   five twenty   seven fifteen   six thirty

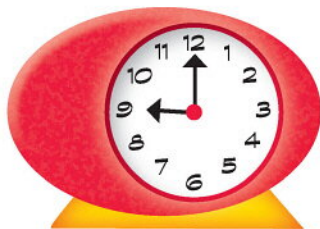

It's nine o'clock.



2 It's .....



3 It's .....



4 It's .....



5 It's .....



6 It's .....

2) Listen. Circle the time you hear.

- 1 10:50 / 10:15   2 12:30 / 12:40   3 2:45 / 2:35   4 5:00 / 9:00   5 11:45 / 7:35   6 5:40 / 5:45

3) What time is it? Listen and draw the times.

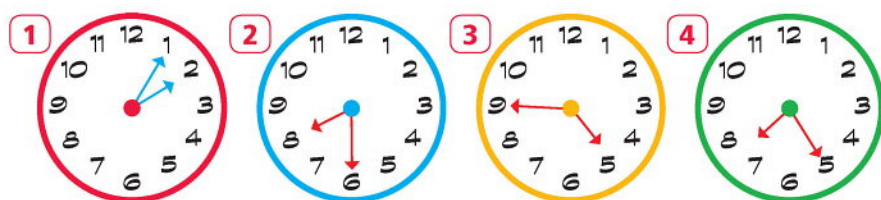

4) **Over to you!**

Ask and answer about the time.  
Student A: *What time is it now?*  
Student B: *It's two thirty.*

## Classroom language

5) Complete the dialogues. Use the questions below.

What does "pencil" mean? Can you repeat that, please? How do you say this in English?  
What page are we on? ~~How do you spell "pen"?~~

1 How do you spell "pen"?

P - E - N.



2 .....

Pencil!

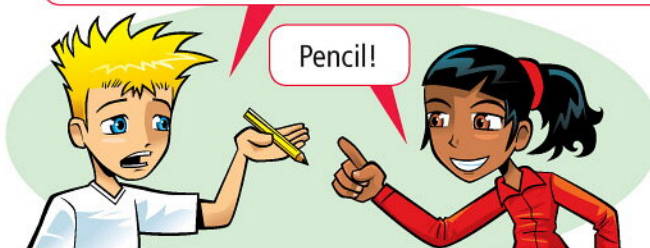

Page 22.

3 .....

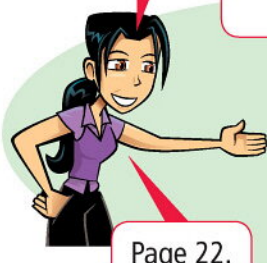

Page 22.

4 .....

5 .....







1 Match the instructions with the pictures. Then listen and repeat.

- Listen  
  Look  
  Match  
  Read  
  Repeat  
  Write

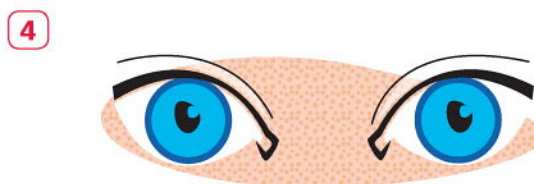
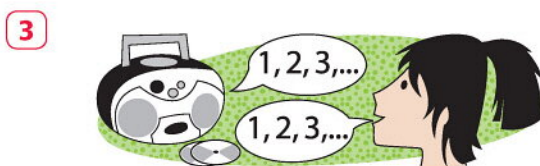
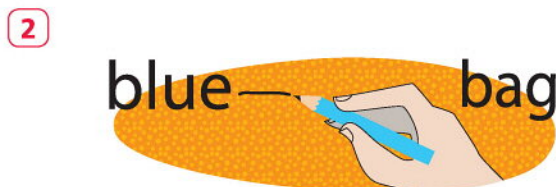

## Subject pronouns

2 Look at the chart.

Singular	Plural
I	we
you	you
he	they
she	
it	

3 Complete the sentences with the words in exercise 1. Then listen, check, and repeat.

1 You are Natalia.

2 \_\_\_\_\_ is Johnny.

3 \_\_\_\_\_ am Anh.

4 \_\_\_\_\_ are Luis and Keiko.

5 \_\_\_\_\_ is Tania.

6 \_\_\_\_\_ are Cristiano and Pedro.



# 1 Identity

## Introducing the topic

### Vocabulary

#### Countries and nationalities

- 1 Match the countries with the words below. Then listen, check, and repeat.

- |                                       |   |
|---------------------------------------|---|
| <input type="checkbox"/> 10 Australia | <input type="checkbox"/> Russia             |
| <input type="checkbox"/> Brazil       | <input type="checkbox"/> South Africa       |
| <input type="checkbox"/> Guatemala    | <input type="checkbox"/> Spain              |
| <input type="checkbox"/> Japan        | <input type="checkbox"/> the United Kingdom |
| <input type="checkbox"/> Mexico       | <input type="checkbox"/> the United States  |

#### Take note!

##### Abbreviations

the United States = the U.S.  
the United Kingdom = the U.K.

- 2 Match the countries in exercise 1 with the nationalities below. Then listen, check, and repeat.

- |                                     |  |
|-------------------------------------|--|
| <input type="checkbox"/> 1 American | <input type="checkbox"/> Japanese      |
| <input type="checkbox"/> Australian | <input type="checkbox"/> Mexican       |
| <input type="checkbox"/> Brazilian  | <input type="checkbox"/> Russian       |
| <input type="checkbox"/> British    | <input type="checkbox"/> South African |
| <input type="checkbox"/> Guatemalan | <input type="checkbox"/> Spanish       |

- 3 Complete the sentences with your country and nationality.

- 1 I'm from .....
- 2 I'm .....

**Puzzle** page 21, puzzle 1



### OBJECTIVES

- countries and nationalities
- *be* (affirmative and questions)
- feelings
- giving personal information
- making introductions
- writing a profile







5



6



7



8



9



10





# Exploring the topic

**TeenTalk** Please [Sign in](#) or [Sign up](#)

**JANUARY 4<sup>TH</sup> 16:45**  
Hi. I'm Vera. I'm fourteen.

**JANUARY 4<sup>TH</sup> 16:47**  
Hi, Vera. My name's Harry. Where are you from?

**JANUARY 4<sup>TH</sup> 16:50**  
I'm from Brazil. And you? Where are you from?

**JANUARY 4<sup>TH</sup> 16:53**  
I'm from the United States. I'm from San Francisco.

**JANUARY 4<sup>TH</sup> 16:55**  
Cool! How old are you?

**JANUARY 4<sup>TH</sup> 17:00**  
I'm fourteen, too.

**TeenTalk** Please [Sign in](#) or [Sign up](#)

**JANUARY 4<sup>TH</sup> 18:05**  
Hello. I'm Mikhail. What's your name?

**JANUARY 4<sup>TH</sup> 18:08**  
My name's Nadia and I'm Spanish. Where are you from, Mikhail?

**JANUARY 4<sup>TH</sup> 18:09**  
I'm Russian. I'm from Moscow, the capital of Russia.

**JANUARY 4<sup>TH</sup> 18:11**  
Wow! How old are you?

**JANUARY 4<sup>TH</sup> 18:14**  
I'm thirteen. How old are you?

**JANUARY 4<sup>TH</sup> 18:20**  
I'm fifteen.

## Reading

**1** Read and listen to the instant chat. Write the name of the person.

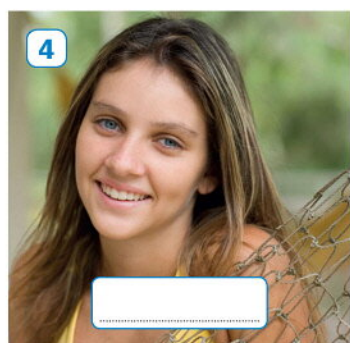
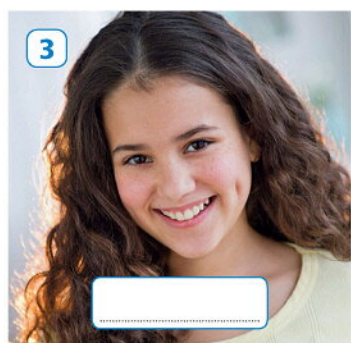
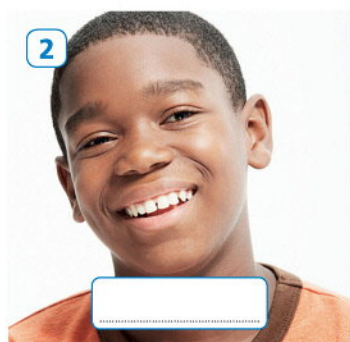

**2** Read again. Match the names with the countries.

- |           |   |            |
|-----------|---|------------|
| 1 Vera    | — | a the U.S. |
| 2 Harry   | — | b Spain    |
| 3 Mikhail | — | c Russia   |
| 4 Nadia   | — | d Brazil   |

**3** Read again. Write V (Vera), H (Harry), M (Mikhail), or N (Nadia).

- |                                  |                   |
|----------------------------------|-------------------|
| 1 "I'm Spanish."                 | <u>  N  </u>      |
| 2 "Cool! How old are you?"       | <u>          </u> |
| 3 "I'm from Moscow."             | <u>          </u> |
| 4 "I'm fourteen, too."           | <u>          </u> |
| 5 "Where are you from, Mikhail?" | <u>          </u> |
| 6 "I'm fifteen."                 | <u>          </u> |
| 7 "I'm from San Francisco."      | <u>          </u> |
| 8 "I'm thirteen."                | <u>          </u> |



## Grammar

### be (questions)

Asking about personal information

#### 1 Look at the chart.

Questions	Answers
What's your name?	I'm Vera. / My name's Vera.
Where are you from?	I'm from Brazil. / I'm Brazilian.
How old are you?	I'm fourteen.

#### 2 Match the questions with the answers.

- |                       |                   |
|-----------------------|-------------------|
| 1 What's your name?   | a I'm twelve.     |
| 2 Where are you from? | b I'm Alex.       |
| 3 How old are you?    | c I'm from Spain. |

#### 3 Fill in the blanks with *Where, What, or How old*. Complete Harry's age.



Harry Styles February 1, 1994

- What ..... 's your name?  
My name's Harry Styles.
- ..... are you from?  
I'm from the U.K.
- ..... are you?  
I'm .....

#### 4 Fill in the blanks with the correct words.



Adriana Lima June 12, 1981

- What's ..... your ..... ?  
..... 's Adriana Lima.
- Where ..... from?  
..... from Brazil.
- ..... are you?  
I'm .....

#### 5 Fill in the blanks with the correct words.



Rafael Nadal June 3, 1986

- What's ..... ?  
My ..... Rafael Nadal.
- .....  
..... ?  
..... from Spain.
- How ..... ?  
.....

## Puzzle

page 21, puzzle 2



#### 6

### Over to you!

You are a famous person. Ask and answer in class.

Student A: What's your name?

Student B: My name's Taylor Swift.

Student A: Where are you from?



# Building the topic



## Vocabulary

### Feelings

1 Label the picture with the words below. Then listen, check, and repeat.

angry bored cold happy hot hungry  
sad scared thirsty tired

### Take note!

- Adjectives never change form in English.  
We're hots. ~~X~~ We're hot. ✓

2 Find the people in the picture. Circle the correct adjective.

- Martin is happy / sad.
- Mary is bored / tired.
- Felipe and Ria are hot / cold.
- Roger is thirsty / hungry.
- Henry is angry / bored.
- Julie and Pablo are cold / scared.

3 Are the sentences true or false for you right now? Circle T or F.

- |                    |                      |
|--------------------|----------------------|
| 1 I'm happy. T / F | 4 I'm hungry. T / F  |
| 2 I'm cold. T / F  | 5 I'm angry. T / F   |
| 3 I'm tired. T / F | 6 I'm thirsty. T / F |



### Grammar

#### be (affirmative)

Talking about feelings

1 Look at the chart.

Affirmative	
Long form	Short form
I am happy.	I'm happy.
You are thirsty.	You're thirsty.
He is cold.	He's cold.
She is scared.	She's scared.
It is sad.	It's sad.
We are bored.	We're bored.
You are hot.	You're hot.
They are angry.	They're angry.

2 Put the words in the correct order to make sentences.

- hungry / is / He He is hungry
- are / happy / We .....
- I / angry / am .....
- are / Anna and Raoul / hot .....
- is / sad / She .....
- hungry / are / You .....

3 Look at the pictures. Fill in the blanks with the correct short form of be.

- We 're hot.      4 He ..... hungry.
- I ..... bored.      5 They ..... angry.
- They ..... cold.      6 She ..... thirsty.



4 Write a sentence for each picture. Use the short form of be.



- We / scared  
We're scared
- She / angry  
.....
- They / sad  
.....

### Puzzle page 21, puzzle 3

5 Over to you!

Mime an adjective from page 14. Can the class guess the adjective?

Student A: (mimes "hot")

Student B: You're hot.

Student A: Yes!



# Living English

2 Hello. My name's Edwina. My nickname is Eddie. I'm thirteen years old and I'm American. I'm from New Jersey. Right now, I'm in Mexico. I'm hot!



2

3 Hi. We're Andrei and Ivan. I'm thirteen and Ivan is eleven. We're from St. Petersburg in Russia. Right now, we're in Canada. We're cold!



3

4 Hello. I'm Conrad. My nickname is Rad. I'm South African. I'm from Johannesburg. I'm fifteen years old. Right now, I'm happy.



4

1 Hi. I'm Kimiko. My nickname is Micky. I'm fourteen years old. I'm from Nagasaki. It's in Japan. Right now, I'm thirsty.



1

## Who are they?

### Reading

1 Look at the Reading skills box.

**Reading skills**

**Scanning**

- You can read the text quickly to find the correct information.

Now scan the profiles. How old is Kimiko? How old is Ivan?

2 Read the profiles. Write each person's name and nationality.

- 1 Kimiko      Japanese
- 2 \_\_\_\_\_
- 3 \_\_\_\_\_ and \_\_\_\_\_
- 4 \_\_\_\_\_

3 Read again. Circle T (True) or F (False).

- 1 Kimiko's nickname is Kim.      T /  F
- 2 Eddie is thirteen years old.      T / F
- 3 Eddie is in New York City.      T / F
- 4 Andrei and Ivan are cold.      T / F
- 5 Conrad's nickname is Rad.      T / F
- 6 Conrad is fourteen years old.      T / F



## Listening

### Giving personal information

- 1 Listen and read. Look at the photos and listen to the conversation. Match the people with the correct flag.

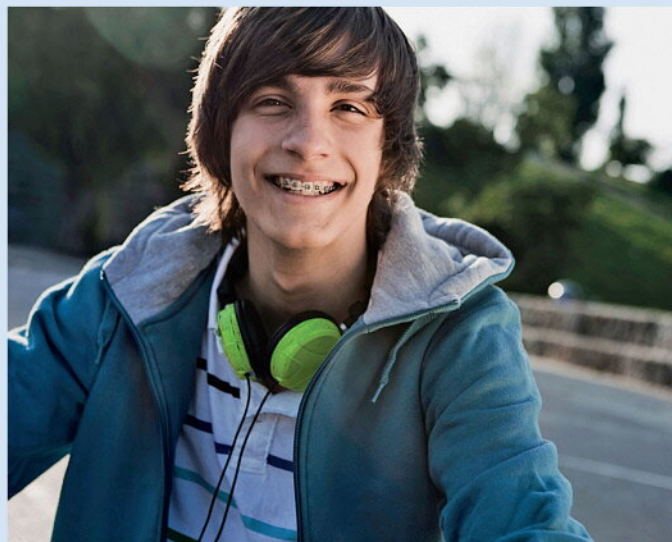

1 Dylan \_\_\_\_\_



2 Maria \_\_\_\_\_

- 2 Listen again. Circle the correct information.

- |  |                       |
|--|-----------------------|
| 1 Dylan is ... .                         | 3 Dylan is ... .      |
| a hungry                                 | a thirteen            |
| b angry                                  | b fourteen            |
| <input checked="" type="radio"/> c happy | c fifteen             |
| 2 It's ... .                             | 4 Maria is from ... . |
| a Saturday                               | a Mexico City         |
| b Sunday                                 | b Monterrey           |
| c Monday                                 | c Merida              |

## Speaking

### Making introductions

- 1 Listen and read.

Hello. I'm **Alex**. What's your name?

Nice to meet you, too.

Hello. I'm **Becky**. Nice to meet you.



He's **David**.

Hi, **David**. How are you?

I'm **OK**. How are you?



I'm **great**.

- 2 Look at the Pronunciation box. Listen to the examples.

### Pronunciation

#### Contractions

- We use short forms when we speak.  
What's your name?  
I'm Becky. / He's David.

Listen again and repeat.

- 3 Listen. Circle the sentence you hear.

- He's a student. / He is a student.
- She's Spanish. / She is Spanish.
- You are fourteen. / You're fourteen.
- We are from Russia. / We're from Russia.

- 4 Practice the dialogue in exercise 1.

- 5 Now change the words in **blue**. Write a new dialogue. Then practice the dialogue in class.



# ROUND-UP

## Writing

### A profile

- 1 Look at the Writing skills box.

#### Writing skills

##### Subject pronouns

- Always use name + verb, or subject pronoun + verb.

Luke is from Australia. **He's** fifteen.

Scott and Alan are fourteen. **They're** Australian.

- 2 Now read the text and circle the subject pronouns.

Luke is from Canberra in Australia. **He's** Australian. **He's** fifteen. Scott and Alan are fourteen. **They're** friends. Right now, **they're** happy.



- 3 Choose a person in your class / school. Fill in the chart with information about the person.

	Example	Your person
Name	Luke	
Town, Country	Canberra, Australia	
Age	15	
Friends	Scott and Alan	
Age	14	
Feelings right now	happy	

- 4 Now write the profile of your person. Use the text and the chart to help you.

## I can ...

- 1 Complete the dialogue.

1 **Juan:** "Hi! My name's Juan.  
 \_\_\_\_\_ Spain.  
 \_\_\_\_\_ Spanish. Where \_\_\_\_\_  
 \_\_\_\_\_ from?"

2 **You:** "Hi! My \_\_\_\_\_  
 \_\_\_\_\_ from \_\_\_\_\_. I'm  
 \_\_\_\_\_."

I can introduce myself and ask who people are.

Yes, I can.  I need more practice.

- 2 Fill in the blanks.

1 Marta is from São Paulo in Brazil.  
She is \_\_\_\_\_ Brazilian.  
 \_\_\_\_\_ sixteen.

2 Julian \_\_\_\_\_ fifteen. \_\_\_\_\_  
 \_\_\_\_\_ from Australia.

3 Pablo and Luis are friends. Right now,  
 \_\_\_\_\_ bored.

I can talk about people.

Yes, I can.  I need more practice.



**puzzle 1**

Unscramble the countries. Then match them to the flags.

- 1 paajN  
Japan \_\_\_\_\_
- 2 ecoMIX  
\_\_\_\_\_
- 3 het etiUnd satSet  
\_\_\_\_\_
- 4 iRsuas  
\_\_\_\_\_
- 5 zIBiar  
\_\_\_\_\_
- 6 tSuho ifAarc  
\_\_\_\_\_
- 7 slauArita  
\_\_\_\_\_
- 8 eht dinteU migKodn  
\_\_\_\_\_



**puzzle 2**

Look at the code. Write the message from Anna. Then answer her question.

A	B	C	D	E	F	G	H	I	J	K	L	M
Y	Z	A	B	C	D	E	F	G	H	I	J	K
N	O	P	Q	R	S	T	U	V	W	X	Y	Z
L	M	N	O	P	Q	R	S	T	U	V	W	X

K'O CPPC. K'O COGTKECP.  
 \_\_\_\_\_  
 YJGTG CTG AQW HTQO?  
 \_\_\_\_\_  
 I'm from \_\_\_\_\_.



**puzzle 3**

Find the words.

I	Q	T	A	M	T	C	X	S	I	O	T
A	V	I	H	U	N	G	R	Y	Z	W	H
D	H	U	O	S	U	E	A	S	H	A	I
O	J	A	T	H	T	P	N	T	I	H	R
S	N	T	P	X	S	I	G	L	E	S	S
G	Y	B	H	P	A	T	R	A	B	I	T
N	T	U	W	T	Y	S	Y	E	R	C	Y
K	K	P	C	S	C	A	R	E	D	A	L
I	N	O	H	A	I	E	D	C	O	L	D
B	O	R	E	D	O	H	S	F	D	E	I

- ANGRY    BORED    COLD    HAPPY    HOT  
 HUNGRY    SAD    SCARED    THIRSTY    TIRED

**puzzle 4**

Use the words with the same color. Order the words to make questions. Then answer them about you.

WHAT'S	ARE
FROM?	YOU
HOW	OLD
ARE	YOUR
YOU?	ARE
NAME?	WHERE
HOW	YOU?

What's your name? \_\_\_\_\_  
 \_\_\_\_\_  
 \_\_\_\_\_



## 2

## My stuff

## Introducing the topic





## Vocabulary

## Describing objects

- 1 Look at the pictures. Fill in the blanks with the adjectives below. Then listen, check, and repeat.

big cheap expensive long ~~new~~  
old short small

- 2 Listen. Check (✓) the correct adjective.

 1 Mark	old <input checked="" type="checkbox"/>	new <input type="checkbox"/>
 2 Lara	big <input type="checkbox"/>	small <input checked="" type="checkbox"/>
 3 Julio	long <input checked="" type="checkbox"/>	short <input type="checkbox"/>
 4 Mei	cheap <input type="checkbox"/>	expensive <input checked="" type="checkbox"/>

- 3 Fill in the blanks with an adjective from exercise 1.

- My pencil case is .....
- My notebook is .....
- My pens are .....
- My cell phone is .....

## OBJECTIVES

- describing objects
- possessive adjectives and possessive 's
- things in a bedroom
- *this / that / these / those*
- objects from the past
- asking about possessions
- writing: favorite things

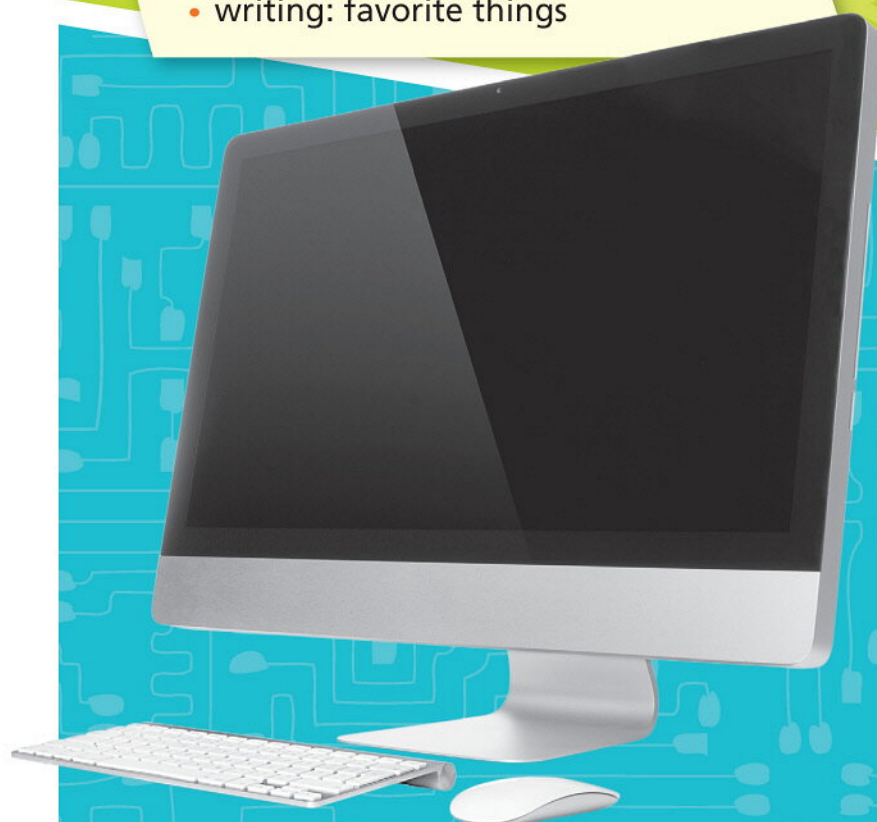

1 The computer is new.

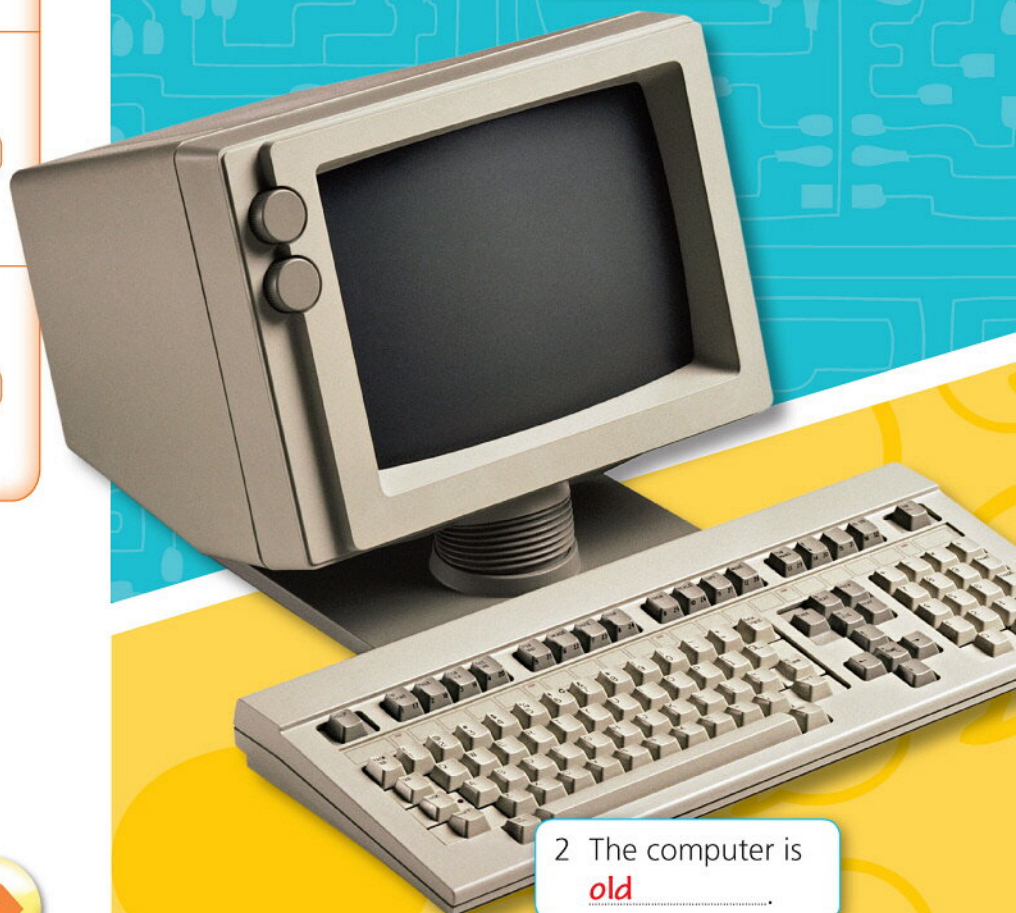

2 The computer is old.

**Puzzle** page 31, puzzle 1 





3 The skateboard is .....



4 The skateboard is .....



5 The tablet is .....



6 The tablet is .....



7 The cell phone is .....



8 The cell phone is .....



# Exploring the topic



1

My name's Zoe. My favorite thing is my skateboard. It's short, and red and yellow. It's old, but it's awesome. I'm happy on it! My friend Katy's skateboard is red, too, but her skateboard is long.



2

My name's Sara. Kevin is my friend. His favorite thing is his MP4 player. It's small and blue, and it's new. His favorite music is on it.



3

My name's Dana and my sister's name is Tami. Our favorite thing is our computer. It's new and expensive, and it's on my desk, not Tami's desk!

## Reading

- 1 Read and listen to the profiles. Match them with the objects below.



a 3



b \_\_\_\_\_



c \_\_\_\_\_

- 2 Read again. Correct the information in blue.

- 1 Zoe's skateboard is long. short
- 2 Katy's skateboard is orange. \_\_\_\_\_
- 3 Kevin's MP4 player is big. \_\_\_\_\_
- 4 His skateboard is new. \_\_\_\_\_
- 5 Dana and Tami's computer is cheap. \_\_\_\_\_
- 6 Tami's sister's name is Tara. \_\_\_\_\_

- 3 Answer the questions.

- 1 What color is Zoe's skateboard?  
red and yellow
- 2 Who is Sara's friend?  
\_\_\_\_\_
- 3 What color is his MP4 player?  
\_\_\_\_\_
- 4 Is Dana and Tami's computer old?  
\_\_\_\_\_



## Grammar

### Possessive adjectives

Talking about possessions

#### 1 Look at the chart.

Subject pronoun	Possessive adjective
I am Zoe.	<b>My</b> skateboard is short.
You are Sara.	<b>Your</b> computer is new.
He is Kevin.	<b>His</b> MP4 player is blue.
She is Dana.	<b>Her</b> cell phone is cheap.
It is a computer.	<b>Its</b> price is \$40.
We are friends.	<b>Our</b> MP4 players are small.
You are sisters.	<b>Your</b> computer is fantastic.
They are friends.	<b>Their</b> phones are old.

#### 2 Fill in the blanks with the correct possessive adjectives.

**My** ..... pen is expensive.

..... notebook is small.



..... pencils are short.

..... eraser is big.



..... ruler is long.

..... bag is old.

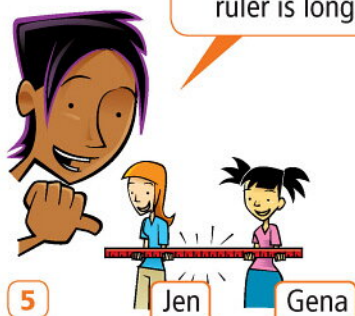

### Possessive 's

Talking about possessions

#### 3 Look at the chart.

##### Possessive 's

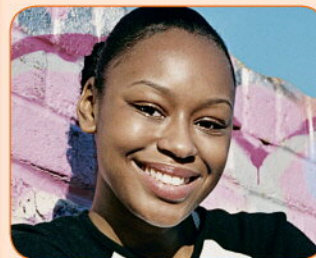

She is Zoe. Her skateboard is short.  
**Zoe's** skateboard is short.

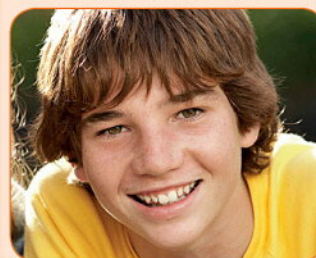

He is Kevin. His MP3 player is blue.  
**Kevin's** MP3 player is blue.

#### 4 Look at the pictures in exercise 2. Fill in the blanks.

- Ricky's** ..... pen is expensive.
- ..... notebook is small.
- Leon's and ..... pencils are short.
- ..... eraser is big.
- Jen and ..... ruler is long.
- ..... bag is old.

## Puzzle

page 31, puzzle 2



#### 5 Over to you!

Say someone's possession. Can the class describe it?

Student A: **Harry's bag.**

Student B: **It's old and black.**



# Building the topic



## Vocabulary

### Things in your bedroom

**1** Look at the picture of Juan's bedroom. Label the objects and furniture with the words below. Then listen, check, and repeat.

**Objects:** game console lamp magazines sneakers **TV** watch  
**Furniture:** bed bedside table bookcase chair closet **desk**

### Take note!

#### Prepositions

on =



in =



under =



**2** Look at the picture again. Fill in the blanks with the correct furniture.

- Juan's computer is on his **bed** .....
- His MP4 player is on his .....
- His skateboard is in his .....
- Juan's bag is on his .....
- His notebooks are on his .....
- His cell phone is on his .....

**3** Look at the picture again. Fill in the blanks with the correct objects.

- Juan's **watch** ..... is red.
- His ..... are green and yellow.
- His ..... are blue and white.
- Juan's ..... is white.
- His ..... is black.
- His ..... is orange.







## Grammar

### this / that / these / those

this / these – talking about things near to us

that / those – talking about things not near to us

#### 1 Look at the chart.

Singular	
This is a TV.	
That is a TV.	
Plural	
These are TVs.	
Those are TVs.	

#### 2 Circle the correct word.

- 1 This / These is my bed.
- 2 That / Those are their skateboards.
- 3 These / This are our watches.
- 4 That / Those is Tia's bed.
- 5 These / This is your pen.
- 6 Those / That are my favorite sneakers.

#### 3 Fill in the blanks with *This*, *That*, *These*, or *Those*.



1 This is my cell phone.



2 \_\_\_\_\_ is my game console.



3 \_\_\_\_\_ are our MP3 players.



4 \_\_\_\_\_ are my magazines.

#### 4 Complete the questions with 's or are, and this, that, these, or those.



Boy: (1) What 's this \_\_\_\_\_?

Girl: It's my school bag.

Boy: (2) What \_\_\_\_\_?

Girl: They're my school books.

Boy: (3) What \_\_\_\_\_?

Girl: They're my favorite magazines.

Boy: (4) What \_\_\_\_\_?

Girl: It's my lamp.

Boy: (5) What \_\_\_\_\_?

Girl: It's my new camera.

Boy: Cool!

## Puzzle

page 31, puzzle 3



#### 5

#### Over to you!

Ask and answer about things in the classroom.

Student A: **What's this?**

Student B: **It's a notebook.**

Student A: **What are those?**



Living English

# OBJECTS FROM THE PAST



**A** These are old TVs from the U.K. in the 1950s. They're black and white TVs, not color. They're big and brown, but their screens are small and white.

**C** This is the world's first cell phone from 1983. It's from the U.S. That thing on top of the phone is an antenna. It's very long!

**B** This is one of the first personal computers in the world. It's American and it's from 1977. It's white and its screen is small.

**D** These are old game consoles from the 1970s. They're big, and their games are big, too.

## Reading

1 Look at the Reading skills box.

### Reading skills

#### Using pictures

- Use the pictures to help you understand what a text is about.

Now look at the pictures and read the articles quickly. What are they about?

- a new electronic things
- b old electronic things
- c cheap electronic things

2 Read the articles again. Match A-D with the pictures 1-4.

- 1 C
- 2 \_\_\_\_\_
- 3 \_\_\_\_\_
- 4 \_\_\_\_\_

3 Read again. Circle the correct words.

- 1 The TVs are American / British.
- 2 They're color / black and white TVs.
- 3 The computer is from 1977 / 1983.
- 4 Its screen is small / big.
- 5 The cell phone is Japanese / American.
- 6 Its antenna is short / long.
- 7 The game consoles are old / new.



## Listening

### Describing your bedroom

- 1 Listen to Lucia. What is her favorite thing in her bedroom?
- 2 Listen again. Draw the objects in the correct place in Lucia's bedroom.



- 3 Listen again. Fill in the blanks with the words below.

expensive cool new big

- 1 Lucia's bedroom is cool.
- 2 Her bed is very .....
- 3 Her MP3 player is .....
- 4 Her sneakers are .....

## Speaking

### Asking about possessions

- 1 Listen and read.



- 2 Look at the Pronunciation box. Listen to the examples.

**Pronunciation**

**th sounds**

- **th** has two different sounds.

/ð/ that	/θ/ thing
-------------	--------------

Listen again and repeat.

- 3 Listen. Put the words in the correct column.

those thirteen thirsty they

/ð/	/θ/
those	

- 4 Practice the dialogue in exercise 1.
- 5 Now change the words in **blue**. Write a new dialogue. Then practice the dialogue in class.



# ROUND-UP

## Writing

### Favorite things

1 Read the text. Complete the text with one of the words below.

camera   ~~cell phone~~   sneakers



### Favorite things

I'm Leah and my favorite thing is my (1) cell phone. It's an MP3 player, too. It's small and pink. Right now, it's in my bag. My friend's favorite thing is her (2) ..... It's black. It's new and expensive. Right now, it's on her desk in her bedroom.

2 Fill in the chart with information about Leah and her friend.

	favorite object	color	other adjective(s)	location right now
Leah	.....	pink	small	.....
her friend	.....	.....	.....	.....
you	.....	.....	.....	.....
your friend	.....	.....	.....	.....

3 Now fill in the chart with information about you and your friend.

4 Write about your favorite things and your friend's favorite things. Use the text and chart to help you.

## I can ...

1 Fill in the blanks with possessive adjectives.

- John's computer is new. His ..... computer is new.
- Patricia's skateboard is old. .... skateboard is old.
- Robert and Paolo's pencils are red. .... pencils are red.
- We are sisters. .... TV is new.

2 Circle the correct word.

- This / those is her computer.
- These / That is my desk.
- This / These are our school books.
- Those / That are his sneakers.

I can talk about things near and not near to me.

Yes, I can.  I need more practice.

I can talk about possessions.

Yes, I can.  I need more practice.



# puzzle 1

- Follow the maze.
- Which adjective is missing?

Start	o	l	Finish
d	l	l	a
e	x	s	m
e	p	g	n
n	s	l	o
v	i	w	e
e	s	p	n
o	h	a	e
r	t	c	h

# puzzle 3

Discover the code and identify the secret word. Then match the words to the pictures.

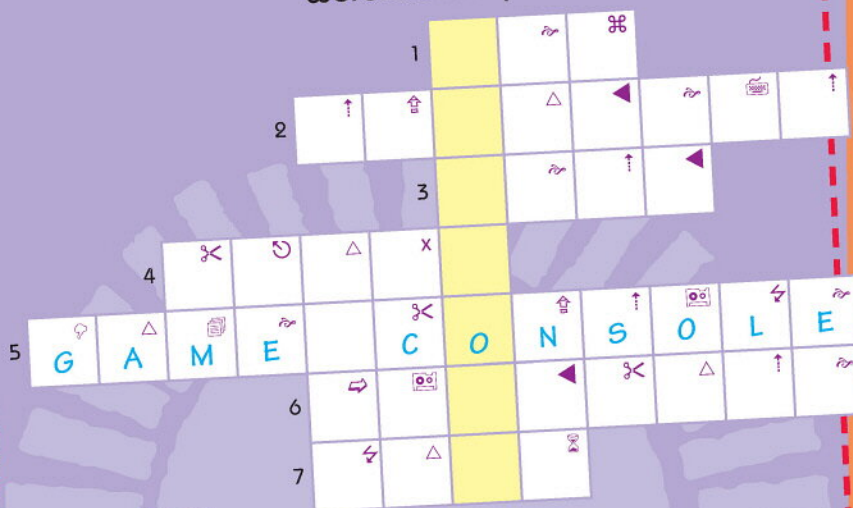

# puzzle 2

Use the letters to complete the sentences. Use the other letters to write Daniel's favorite thing.

R	O	E	E
H	K	D	R
<del>S</del>	<del>Y</del>	B	S
T	<del>H</del>	H	R
R	<del>X</del>	T	A
T	O	A	I
S	E	I	M
	U		

- This is Daniel. HIS cell phone is expensive.
- \_\_\_\_\_ price is \$200.
- His best friend is Spanish. \_\_\_\_\_ name is Bruna.
- Bruna is in Daniel's class. \_\_\_\_\_ class is big.
- Daniel and Bruna: "\_\_\_\_\_ English teacher is American."
- Daniel: "\_\_\_\_\_ English book is blue."  
His favorite thing is his SK \_\_\_\_\_.

# puzzle 4

Look at the chart. Then complete the sentences with words from the box.

Name	Favorite color	How many cell phones?
Jacob	white	1
Amanda	pink	2
Julia	black	1
Rob	blue	2

That    These    Julia's    Rob's    Those  
Amanda's    This    Jacob's

- \_\_\_\_\_ are \_\_\_\_\_ cell phones.
- \_\_\_\_\_ is \_\_\_\_\_ cell phone.
- \_\_\_\_\_ is \_\_\_\_\_ cell phone.
- \_\_\_\_\_ are \_\_\_\_\_ cell phones.



# A Review

## Vocabulary

### Countries and nationalities

1 Fill in the blanks with the correct country or nationality.

- 1 Natalia is from Russia.  
She's Russian.
- 2 Taro is from .....  
He's Japanese.
- 3 Kim is from South Africa.  
She's .....
- 4 Rob is from .....  
He's Australian.
- 5 Geri is from the U.K.  
She's .....
- 6 Judd is from .....  
He's American.

### Feelings

2 Look at the pictures. Unscramble the adjectives.

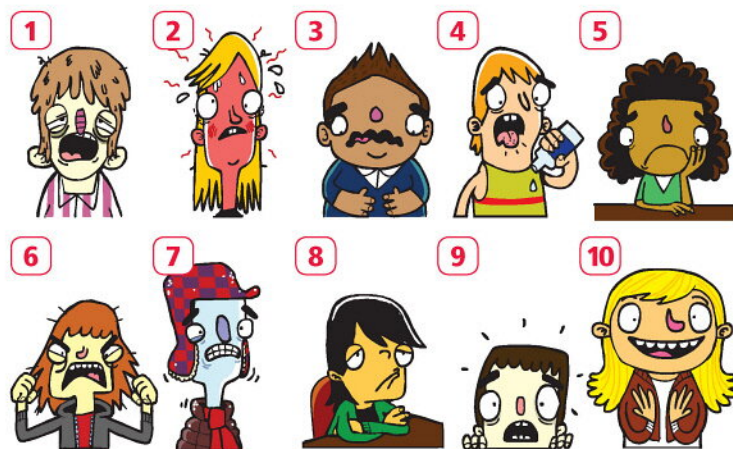

- 1 rdtei tired
- 2 oth
- 3 nrguyh
- 4 hirtyst
- 5 ads
- 6 ragyn
- 7 odcl
- 8 bdeor
- 9 cdsear
- 10 phyap

## Describing objects

3 Fill in the blanks with the words below.

big cheap expensive long  
new old short small



- 1 Your skateboard is long.  
My skateboard is short.
- 2 His dog is .....  
My dog is .....



- 3 Your sneakers are .....  
My sneakers are .....
- 4 This MP3 player is .....  
That MP3 player is .....

## Things in your bedroom

4 Find ten things in your bedroom in the word snake.





## Grammar

### be (questions)

#### 1 Write the questions.

You: What's your name .....

Nelly: My name's Nelly.

You: .....

Nelly: I'm from the United States.

You: .....

Nelly: I'm fourteen.

### be (affirmative)

#### 2 Fill in the blanks with the correct form of be.

1 He 's ..... from Canberra in Australia.

2 We ..... happy right now.

3 My skateboard ..... under my bed.

4 I ..... thirsty.

5 You ..... Luca's friend.

6 They ..... thirteen.

### Possessive adjectives

#### 3 Fill in the blanks with the correct possessive adjective.

1 My ..... name's Tomiko and I'm from Japan.

2 This is my friend Maximillian. ....  
nickname is Max.

3 "What's ..... name?"  
"My name's Alicia."

4 Susie and ..... friend are happy.

5 Pavel and Lydia are hot. .... friends are cold.

6 We are twelve. .... friend is thirteen.

### Possessive 's

#### 4 Rewrite the information in one sentence.

1 He is Paul. His computer is old.  
Paul's computer is old .....

2 They are Jan and Lara. Their sneakers are red.  
.....

3 She is Erica. Her TV is big.  
.....

4 He is Marcus. His watch is black.  
.....

5 She is Lucy. Her bed is short.  
.....

### this / that / these / those

#### 5 Fill in the blanks with *this*, *that*, *these*, or *those*.



1 This ..... is my watch.

2 ..... are my magazines.

3 ..... is my cell phone.

4 ..... are my pencils.

5 ..... is my MP3 player.

### Study skills

#### Recording vocabulary

Make a vocabulary section for new words in your notebook. Draw pictures, and write example sentences and translations. For adjectives, write opposites.

#### 1 Look at the notes. Which words does the student want to remember?

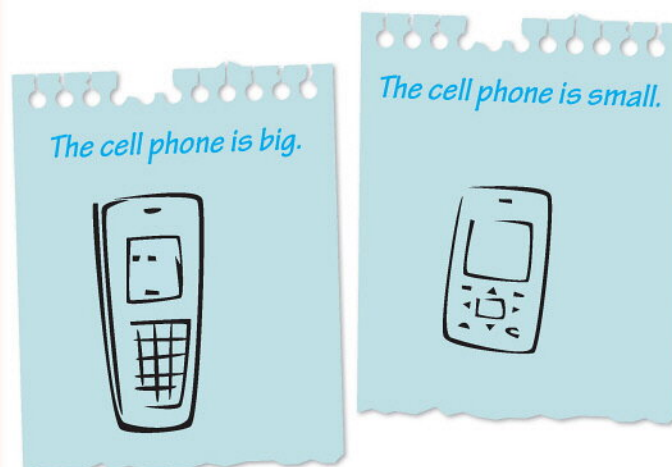

#### 2 Add the words to your vocabulary section. For each word, draw a picture. Write an example sentence and a translation.

bed bedside table expensive hot



# engage

# Magazine A



**1** Match sentences 1-4 with the pictures a-d.

**1** This is Vincent van Gogh. He is a famous artist.

**2** He's from the Netherlands.

**3** His paintings are in museums.

**4** His paintings are very expensive.

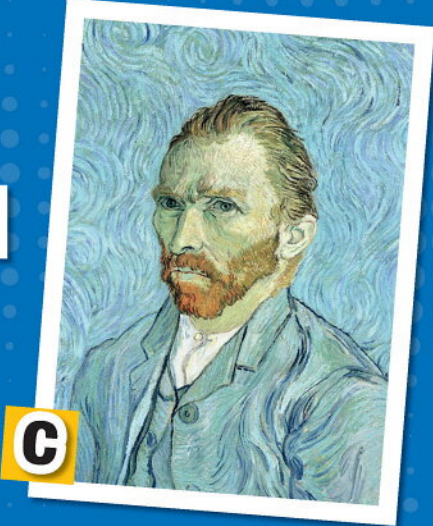
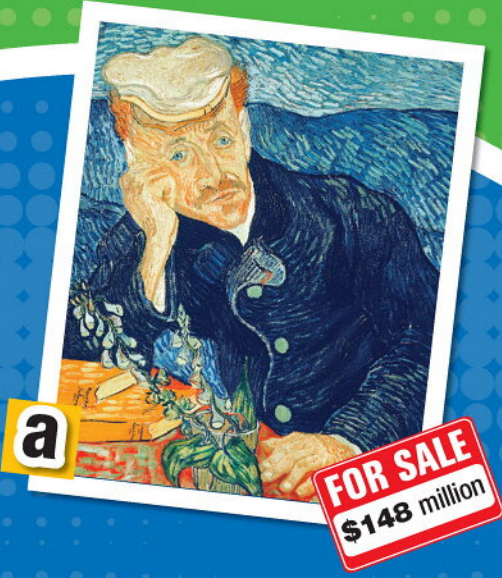

**2** This is van Gogh's bedroom. Write the words.

- chair
- bed
- paintings
- ~~mirror~~
- table

- 
- 
- 
- 
- 

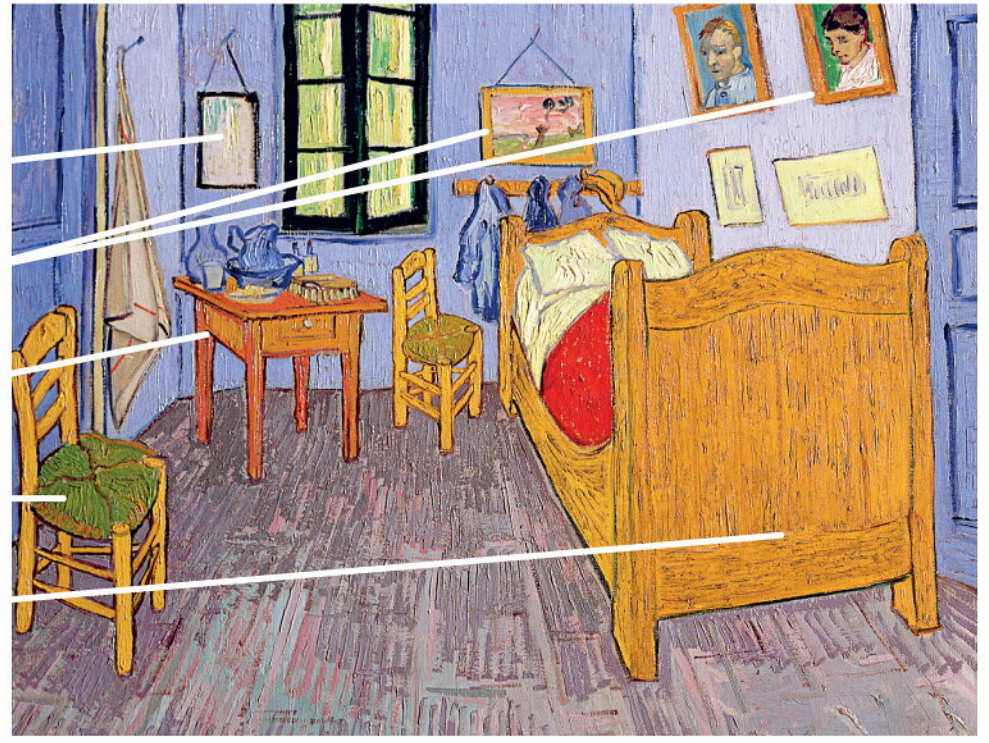



### 3

Put the words in the correct box.

blue yellow black green purple  
white ~~red~~ pink gray orange brown

**Warm**

red

**Cool**

**Neutral**



### 4

Fill in the blanks.



I like (1)

It's a happy color.

Happy? No, blue is sad. I like (2)

Yellow is happy.

### 5

**Over to you!**

Talk to a friend about colors you like. Talk about your feelings about the colors.

**Student A:** I like green. Green is happy.

**Student B:** I like purple. Purple is beautiful.

### 6

**Project**

This is *Starry Night*, by Vincent van Gogh. He's from the Netherlands. The colors are blue, green, yellow, and black. They're cool, warm, and neutral. The painting is beautiful.

- 1 Choose a famous painting.
- 2 Find a picture of the painting or reproduce it yourself.
- 3 Make a poster about the painting. Answer the questions.
  - Who is the artist?
  - Where is the artist from?
  - Are the colors warm, cool, or neutral?
  - Is the painting happy, sad, beautiful ...?





# 3

## Favorite people

### Introducing the topic

#### Vocabulary

##### Jobs

1  Label the photos with the words below. Then listen, check, and repeat.

actor artist athlete dancer doctor model  
 singer skateboarder soccer player writer

#### Take note!

a / an

She's a doctor.  
 He's an actor.

He's a singer.  
 She's an artist.

2 Look at the pictures. Write the correct job.



1 writer



4 \_\_\_\_\_



2 \_\_\_\_\_



5 \_\_\_\_\_



3 \_\_\_\_\_



6 \_\_\_\_\_

3 Complete the sentences with a name.

1 \_\_\_\_\_ is a soccer player.

2 \_\_\_\_\_ is a singer.

3 \_\_\_\_\_ is an actor.

4 \_\_\_\_\_ is an athlete.

#### OBJECTIVES

- jobs
- be (negative and yes / no questions)
- family
- famous people
- talking about people and their jobs
- writing: an e-mail



1 Bob Burnquist  
skateboarder



2 Marianela Nuñez  
 \_\_\_\_\_

**Puzzle**

page 45, puzzle 1





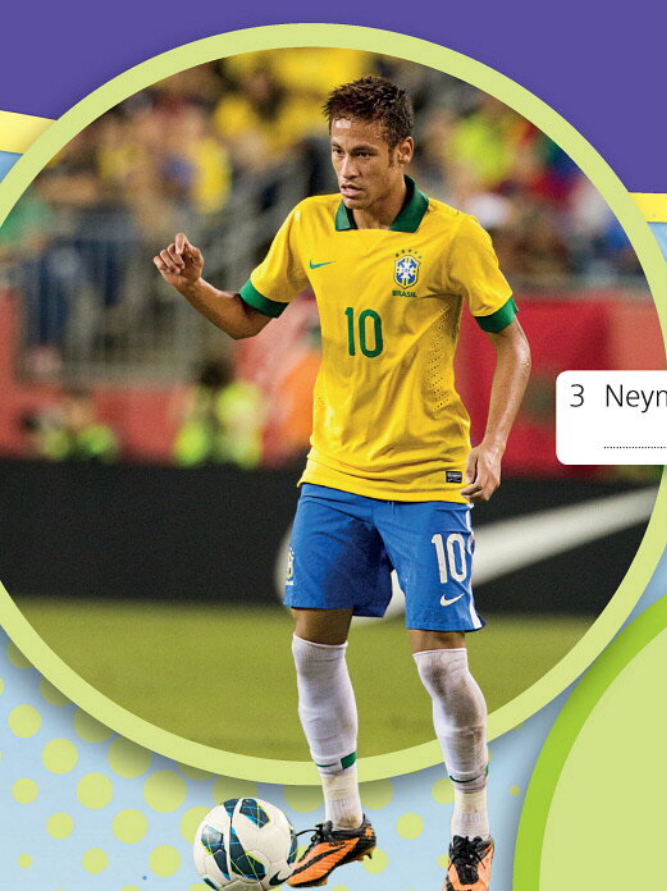

3 Neymar

4 Magdi Yacoub

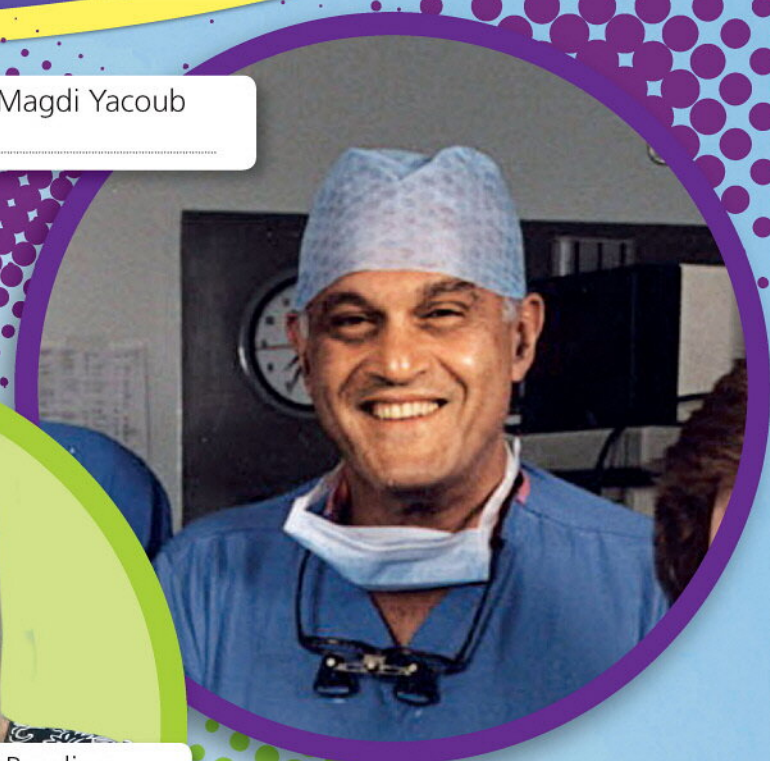

5 J.K. Rowling



6 Isabeli Fontana



8 Sandra Bullock



7 Rihanna

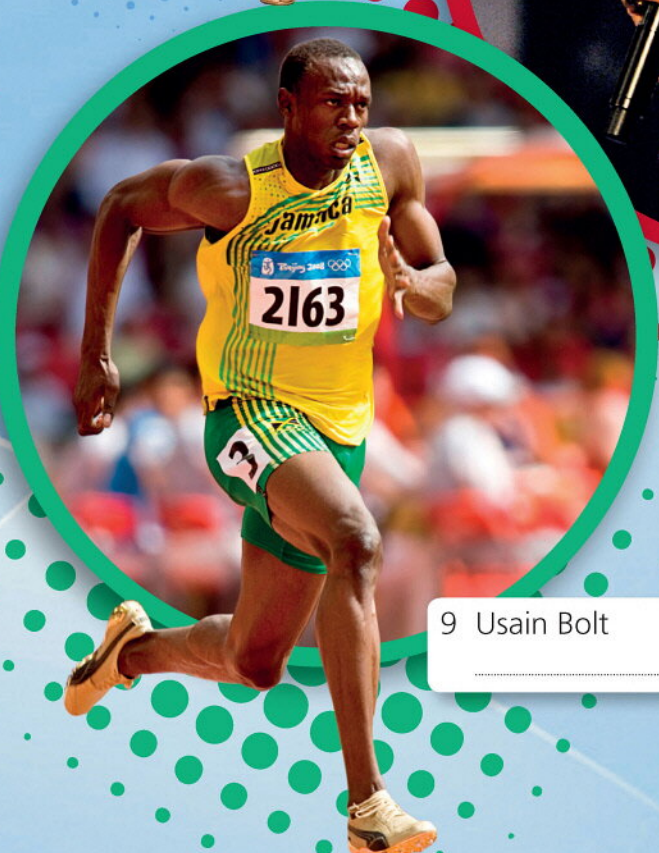

9 Usain Bolt



10 Takashi Murakami



## Exploring the topic

### Who is your favorite person?

My favorite person is Cristiano Ronaldo. He's from Portugal and he's a soccer player. He's fantastic! He isn't only a soccer player. He's a model, too. His pictures are in fashion magazines.

Miriam, 15



My favorite person is the actor Lea Michele. She's from the United States and her date of birth is August 29, 1984. Lea isn't only an actor. She's a singer, too. She is on the TV show *Glee*. She's a great singer!

Luis, 14

My favorite person is Emma Watson. She is a British actor. In the *Harry Potter* movies, Emma is Hermione. She is in lots of other movies, too. She's in my favorite movie, *The Bling Ring*. But Emma isn't only an actor. She's a model, too. And she's a student, at universities in the U.S. and the U.K.

Paula, 13

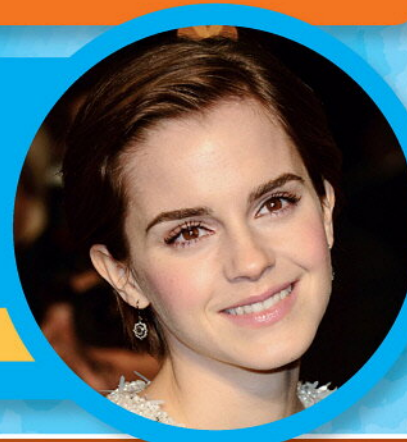

## Reading

**1** Look at the photos. Who are the people? What are their main jobs?

**2** Guess what their other jobs are. Choose from the jobs below. Then read and listen, and check your answers.

model

singer

**3** Read again. Circle T (True) or F (False).

- |                                    |  |
|------------------------------------|--|
| 1 Cristiano Ronaldo is Portuguese. | <input checked="" type="radio"/> T / F |
| 2 He isn't a singer.               | T / F                                  |
| 3 Lea Michele is Australian.       | T / F                                  |
| 4 Her birthday is in August.       | T / F                                  |
| 5 Emma Watson is from the U.S.     | T / F                                  |
| 6 She is a model.                  | T / F                                  |

**4** Read again. Answer the questions.

1 What is Miriam's opinion of Ronaldo?

he's fantastic

2 Where are his pictures?

3 How old is Lea Michele?

4 What's the name of the TV show she's on?

5 What is Paula's favorite movie?

6 Where is Emma Watson a student?



## Grammar

### be (negative)

Talking about jobs and personal information

#### 1 Look at the chart.

Negative	
Long form	Short form
I <b>am not</b> an actor.	I' <b>m not</b> an actor.
You <b>are not</b> an artist.	You <b>aren't</b> an artist.
He / She / It <b>is not</b> fantastic.	He / She / It <b>isn't</b> fantastic.
We <b>are not</b> models.	We <b>aren't</b> models.
You <b>are not</b> singers.	You <b>aren't</b> singers.
They <b>are not</b> athletes.	They <b>aren't</b> athletes.

#### 2 Circle the correct words.

- Tae-Min is not / are not from Japan.
- Sally and Paul are not / is not models.
- Teri and I are not / is not Italian.
- I is not / am not hungry.
- Angelo is not / are not a writer.
- You are not / is not sixteen.

#### 3 Look at the pictures. Fill in the blanks with the affirmative and negative short form of *be*.



- 1 I 'm ..... an artist.  
I 'm not ..... a writer.



- 2 We ..... models.  
We ..... dancers.



- 3 He ..... a singer.  
He ..... a model.



- 4 They ..... actors.  
They ..... soccer players.



- 5 She ..... an athlete.  
She ..... a doctor.



- 6 You ..... an athlete.  
You ..... an artist.

#### 4 Make these sentences true for you.

- I ..... twelve.
- My teacher ..... from Australia.
- I ..... in eighth grade.
- My friends ..... from the U.K.
- We ..... in an English class.
- I ..... Brazilian.

### Puzzle

page 45, puzzle 2



#### 5 Over to you!

Write three false sentences and one true sentence about people. Use the affirmative. Can the class correct the false sentence?

Student A: Kaká is an actor.

Student B: No! Kaká isn't an actor. He's a soccer player.



# Building the topic

## Vocabulary

### Family

1) Fill in the blanks in the family tree with the words below. Then listen, check, and repeat.

brother father **grandfather** grandmother  
grandparents mother parents sister

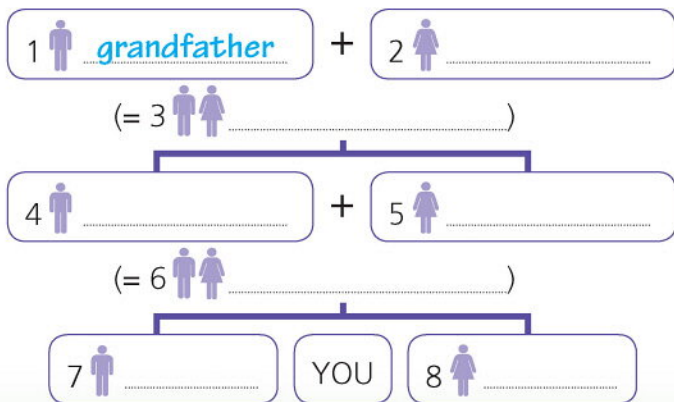

2) Read and listen to the story. Then answer the questions about Laura's family.

- 1 Who is a musician? her mother
- 2 Who is 85? \_\_\_\_\_
- 3 Who are five? \_\_\_\_\_
- 4 Who is an artist? \_\_\_\_\_
- 5 Who is Kath? \_\_\_\_\_
- 6 Who is Dave? \_\_\_\_\_

3) Write about the names of people in your family. Choose three words from exercise 1.

*My father's name is Eduardo.*

- 1 \_\_\_\_\_
- 2 \_\_\_\_\_
- 3 \_\_\_\_\_

# My family

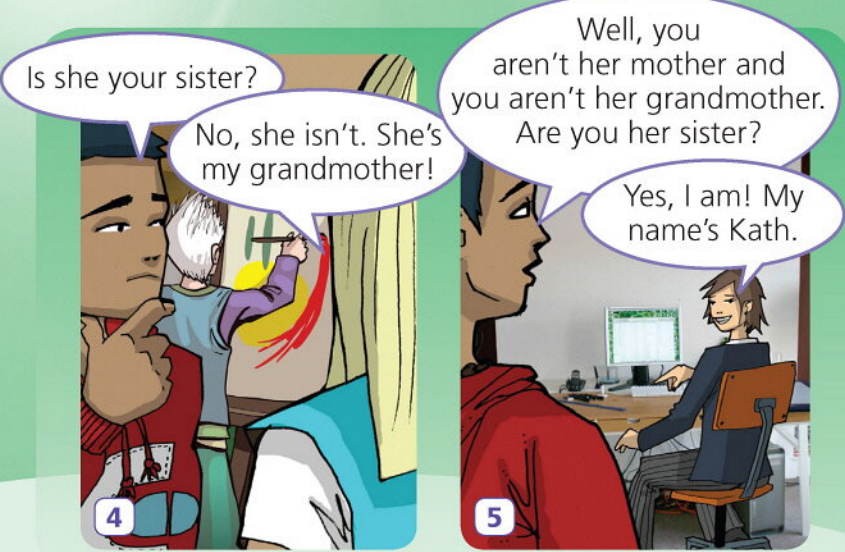



### Grammar

#### be (yes / no questions)

Asking and answering about people and things

#### 1 Look at the chart.

Long form	Short form
Am I a dancer?	Yes, <b>I am.</b> / No, <b>I'm not.</b>
Are you a singer?	Yes, <b>you are.</b> / No, <b>you aren't.</b>
Is he your father?	Yes, <b>he is.</b> / No, <b>he isn't.</b>
Is she your mother?	Yes, <b>she is.</b> / No, <b>she isn't.</b>
Is it your house?	Yes, <b>it is.</b> / No, <b>it isn't.</b>
Are we friends?	Yes, <b>we are.</b> / No, <b>we aren't.</b>
Are you brothers?	Yes, <b>you are.</b> / No, <b>you aren't.</b>
Are they models?	Yes, <b>they are.</b> / No, <b>they aren't.</b>

#### 2 Complete the questions about Laura's family.



1 **Are** you Laura's mother?



2 ..... he Laura's brother?



3 ..... her sister?



4 ..... they her brothers?



5 ..... her grandfather?



6 ..... her sister?

#### 3 Match the questions in exercise 2 with the answers below.

- a Yes, he is. ....
- b No, she isn't. ....
- c Yes, they are. ....
- d No, he isn't. ....
- e Yes, she is. ....
- f No, I'm not. 1

#### 4 Look at the pictures. Write short answers for the questions.

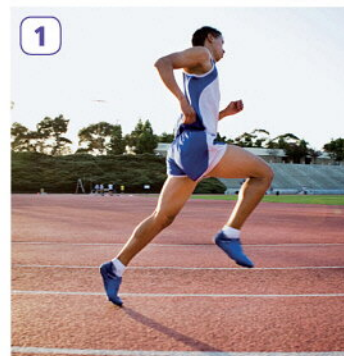

- 1 Are you an actor? **No, I'm not** .....
- 2 Is he a skateboarder? .....
- 3 Are they soccer players? .....
- 4 Are we artists? .....
- 5 Is she a singer? .....
- 6 Are you an artist? .....

### Puzzle page 45, puzzle 3



#### 5 Over to you!

Write the names of four people in your family. Ask and answer in class.

- Student A: **Is Marco your brother?**
- Student B: **No, he isn't.**
- Student A: **Is he your father?**
- Student B: **Yes, he is.**



# Living English

# FAMOUS PEOPLE QUIZ

## Reading

**1**



**PENÉLOPE CRUZ** is an actor from Spain. Her sister **Mónica** is famous, too. Is she ... ?

- a a dancer
- b a dancer and actor
- c a dancer, actor, and model

**2**



**WES STROMBERG** is a singer and guitarist from the United States. He is in a band with his brother **Keaton Stromberg** and his friend, **Drew Chadwick**. Is the band's name ... ?

- a One Direction
- b Maroon 5
- c Emblem3

**3**



**ROBERT PATTINSON** is an actor from the U.K. His sister **Lizzy** is famous, too. Is she ... ?

- a a model
- b a dancer and actor
- c a singer and songwriter

**4**



**WAYNE AND JOHN ROONEY** are British brothers. They aren't singers, songwriters, or dancers. Are the two brothers famous ... ?

- a athletes
- b models
- c actors

**5**



**SERENA WILLIAMS** is a professional tennis player from the U.S. Another person in her family is a famous tennis player, too. Is it ... ?

- a her mother
- b her sister
- c her brother

**6**



**JADA PINKETT SMITH AND WILL SMITH** are American actors. They are famous parents, too. Are **Jaden** and **Willow** ... ?

- a Jada's parents
- b Will's brother and sister
- c their children

**1** Look at the Reading skills box.

**Reading skills**

**Predicting**

- You can predict vocabulary in a text before you read.

Now look at the names in the quiz. Write what you know about the people.

*Penélope Cruz, Spanish, actor?*

**2** Do the quiz. Check your answers at the bottom of the page.

**3** Read again. Write the names.

- 1 She's a tennis player. Serena Williams
- 2 They're a British brother and sister.  
.....
- 3 He's in a band with his brother and his friend.  
.....
- 4 She is a mother and he is a father.  
..... and  
.....
- 5 She's an actor from Spain.  
.....
- 6 They're brothers from the U.K.  
.....

Answers 1c 2c 3c 4a 5b 6c



Favorite people

Listening

Talking about your family



1 Listen and read. Look at the photo and listen to the conversation. Answer the questions about Anna.

- 1 What's her job? tennis player
- 2 How old is she? \_\_\_\_\_
- 3 Where is she from? \_\_\_\_\_

2 Listen again. Fill in the chart about Anna's family with the words below.

doctor	<u>David</u>	Helena
Maria	soccer player	writer

	Name	Job
father	<u>David</u>	_____
mother	_____	_____
sister	_____	_____

Speaking

Talking about people and their jobs

1 Listen and read.



2 Look at the Pronunciation box. Listen to the examples.

**Pronunciation**

**Intonation in questions**

- Intonation goes up (↗) at the end of *yes / no* questions.
- It goes down (↘) at the end of *Wh-* questions.

Is that your brother? What's his name?

Listen again and repeat.

3 Listen. Put ↗ or ↘.

- 1 How old is she? ↘
- 2 Are they your parents? ↗
- 3 Is he a doctor? ↗
- 4 Where are you from? ↘

4 Practice the dialogue in exercise 1.

5 Now change the words in blue. Write a new dialogue. Then practice the dialogue in class.



# ROUND-UP

## Writing

### An e-mail about your family

1 Read the e-mail. Who is Megan? Who is Holly?

● ● ●
✉

Hi Tomomi,  
 My family is cool! My father is a teacher. His name is Andrew. My mom's name is Megan and she's an artist. My sister's name is Holly and she's sixteen. She's a student. My brother is a singer. He's twenty-two and his name is Brett. What about your family?  
 Write soon,  
 Chrissy



2 Fill in the chart with information about Chrissy's family.

	Name	Age	Job
Chrissy's father	Andrew	-	teacher
Chrissy's mother	.....	-	.....
Chrissy's sister	.....	.....	.....
Chrissy's brother	.....	.....	.....
my	.....	.....	.....
my	.....	.....	.....
my	.....	.....	.....
my	.....	.....	.....

3 Now fill in the chart with information about your family.

4 Write an e-mail about your family. Use the text and the chart to help you.

## I can ...

1 Complete the sentences with *is / isn't / are / aren't*.

- Lionel Messi *is* ..... a soccer player.
- J.K.Rowling and Stephen King ..... actors.
- Lady Gaga ..... a skateboarder.
- Penélope Cruz and Zac Efron ..... actors.

I can talk about jobs and personal information.

Yes, I can.  I need more practice.

2 Answer the questions.

- Are you a student? *Yes, I am* .....
- Are you sixteen? .....
- Are you Mexican? .....
- Is your favorite soccer player Lionel Messi?  
 .....

I can answer questions about myself.

Yes, I can.  I need more practice.



# puzzle 1

Unscramble the words. Use the letters in the circles to make another job.

O C **T** A R    ACTOR \_\_\_\_\_

N E **D** C A R    \_\_\_\_\_

S C E **C** R O    L P E Y R A    \_\_\_\_\_

D E **O** L M    \_\_\_\_\_

**R** I R T W E    \_\_\_\_\_

E **O** K A T D S R A B E R    \_\_\_\_\_



"I AM A \_\_\_\_\_."

# puzzle 2

BREAK THE CODE AND WRITE THE SENTENCES.

A	B	C	D	E	F	G	H	I	J	K	L	M
8				6				16				
N	O	P	Q	R	S	T	U	V	W	X	Y	Z

I'    A    A    E    A    E .  
 16 20    15 13 4    8    2 1 8 4 6 12 13 8 14 13 6 14

I'    A    A    E    E .  
 16 20    8 15    8 4 11 21 6 4 6

# puzzle 3

Read the sentences and answer the questions.

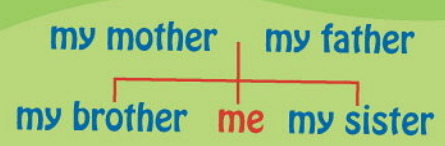

- 1 Jim isn't my brother.
- 2 Carol isn't Tom's mother.
- 3 Tom isn't Carol's father.
- 4 Delia isn't Tom's sister.

Who is my mother / father / brother / sister?

# puzzle 4

## Do the celebrity quiz!

- |   |  |   |
|---|--|---|
| 1 Are singers Jorge and Mateus brothers?    | <input type="checkbox"/> a) Yes, they are.   | <input type="checkbox"/> b) No, they aren't.  |
| 2 Is Mila Kunis an actor or a singer?       | <input type="checkbox"/> a) She's an actor.  | <input type="checkbox"/> b) She's a singer.   |
| 3 Are Angelina Jolie and Brad Pitt parents? | <input type="checkbox"/> a) Yes, they are.   | <input type="checkbox"/> b) No, they aren't.  |
| 4 Is Katy Perry American or Canadian?       | <input type="checkbox"/> a) She's American.  | <input type="checkbox"/> b) She's Canadian.   |
| 5 Is Sarah Menezes an athlete or an artist? | <input type="checkbox"/> a) She's an artist. | <input type="checkbox"/> b) She's an athlete. |
| 6 Is Bruno Mars Lady Gaga's brother?        | <input type="checkbox"/> a) Yes, he is.      | <input type="checkbox"/> b) No, he isn't.     |

Check your score!  
 4-6 correct: Congratulations! You're probably a celebrity, too!  
 2-3 correct: Good job!  
 0-1 correct: It's OK. TV and movies aren't very important!

Answers  
 1b 2a 3a 4b 5b 6b



## 4

## Favorite places

## Introducing the topic

## Vocabulary

## Nature

- 1  Label the photos with the words below. Then listen, check, and repeat.

**Places:** beach forest lake mountain  
river waterfall

**Animals:** bird butterfly fox monkey

## Take note!

## Plural nouns

a lake	lakes	a fox	foxes
a beach	beaches	a butterfly	butterflies

- 2 Complete the sentences with the plural of the words in parentheses.

- The monkeys are small. (monkey)
- The ..... are blue and yellow. (butterfly)
- The ..... are big. (waterfall)
- The ..... are in the U.S. (beach)
- The ..... are in the forest. (fox)

- 3 Complete the sentences with words from exercise 1.

- Mount Everest is a mountain in Asia.
- A capuchin is a kind of .....
- The Nile is a ..... in Africa.
- The Niagara Falls are .....
- A toucan is a kind of .....

- 4 Write sentences about nature in your country.

*The Amazon is a river in Brazil.*

## OBJECTIVES

- nature
- *there is / there are*
- places in a town
- prepositions of place
- describing your hometown
- asking for directions
- writing: a description of a place



1 mountain



2 .....

**Puzzle** page 55, puzzle 1







3 .....



4 .....



5 .....



6 .....



7 .....



8 .....

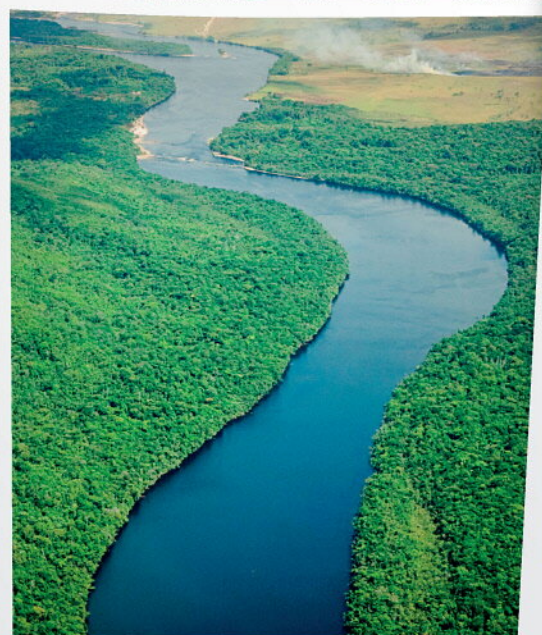

9 .....



10 .....



## Exploring the topic

There are some awesome natural things to see in the world, and one of them is Iguazu Falls in South America. Iguazu Falls are waterfalls on the Iguazu River. There are 275 waterfalls in all!

Wow! 275 waterfalls. Is there a really spectacular one?

Yes, there is. It's called the Devil's Throat. It's 700 meters long and 82 meters high. Part of the Devil's Throat is in Brazil and the other part is in Argentina.

Are there any butterflies or birds?

Yes, there are. There is a national park on both sides of the Iguazu River in Brazil and in Argentina. This tropical forest is the home of thousands of animals. There are 250 kinds of butterflies and 340 kinds of birds. It's incredible!



## Reading

**1** Read and listen to the blog. Choose a title.

- a Famous rivers in the world
- b Animals around the world
- c A natural wonder of the world

**2** Read the blog again and find the names.

- 1 a continent South America
- 2 a river \_\_\_\_\_
- 3 two countries \_\_\_\_\_
- 4 a waterfall \_\_\_\_\_
- 5 two animals \_\_\_\_\_

**3** Read again. Circle T (True) or F (False).

- 1 Iguazu Falls are in the U.S. T /  F
- 2 They're on the Iguazu River. T / F
- 3 There are 275 waterfalls in the Devil's Throat. T / F
- 4 The Devil's Throat is in two countries. T / F
- 5 The national park is a tropical forest. T / F
- 6 There are 100 butterflies in it. T / F



## Grammar

### there is / there are

Talking about what exists in a place

#### 1 Look at the chart.

Affirmative	
Singular	Plural
There is a mountain.	There are mountains.
There's a river.	There are three rivers.

#### 2 Look at the picture of the animal park. Fill in the blanks with *There is* or *There are*.



- 1 *There are* ..... two tigers.
- 2 ..... a panda.
- 3 ..... two dolphins.
- 4 ..... a whale.
- 5 ..... three penguins.
- 6 ..... a bear.

#### 3 Look at the chart.

##### Questions and short answers

Singular	Plural
Is there a waterfall?	Are there any birds?
Yes, <b>there is</b> .	Yes, <b>there are</b> .
No, <b>there isn't</b> .	No, <b>there aren't</b> .

#### 4 Complete the questions and answers about the animal park in exercise 2.

- 1 A: Are there any penguins?  
B: Yes, there (1) *are* .....
- 2 A: Are there any tigers?  
B: Yes, there (2) .....
- 3 A: Is there a panda?  
B: Yes, (3) .....
- 4 A: (4) ..... any butterflies?  
B: No, (5) .....
- 5 A: (6) ..... a whale?  
B: Yes, (7) .....
- 6 A: (8) ..... any monkeys?  
B: No, (9) .....

## Puzzle

page 55, puzzle 2



#### 5 Over to you!

Think of a favorite place. Write three sentences about the place. Use words from page 37.

*There is a mountain.*

*There are monkeys.*

Now tell the class. Can they guess the place?



# Building the topic

## Vocabulary

### Places in a town

1 Match the photos with the words below. Then listen, check, and repeat.

- |   |  |
|---|--|
| <input checked="" type="checkbox"/> bookstore | <input type="checkbox"/> movie theater |
| <input type="checkbox"/> clothes store        | <input type="checkbox"/> bus stop      |
| <input type="checkbox"/> cybercafé            | <input type="checkbox"/> restrooms     |
| <input type="checkbox"/> fast food restaurant | <input type="checkbox"/> sports store  |



2 Listen. Where are the people? Write words from exercise 1.

- 1 bus stop
- 2 \_\_\_\_\_
- 3 \_\_\_\_\_
- 4 \_\_\_\_\_
- 5 \_\_\_\_\_

3 Look at the symbols. Complete the sentences with the correct places.



Jake, 13

There's a (1) movie theater across from a bookstore.

There's a (2) \_\_\_\_\_ between the movie theater and a

(3) \_\_\_\_\_.

There's a (4) \_\_\_\_\_ next to the fast food restaurant.

There are (5) \_\_\_\_\_ across from the fast food restaurant.

There's a (6) \_\_\_\_\_ in front of the shopping mall.



**Grammar**

**Prepositions of place**

Talking about position

**1 Look at the chart.**

Questions and short answers	
Where is the sports store? It's <b>across from</b> the bookstore.	
Where are the restrooms? They're <b>next to</b> the bookstore.	
Where is the cybercafé? It's <b>between</b> the sports store and the movie theater.	
Where is the bus stop? It's <b>in front of</b> the shopping mall.	

**2 Look at the picture of Busy Street below. Write complete sentences.**

- bookstore / cybercafé  
The bookstore is **next to** the cybercafé.
- bus stop / cybercafé  
The bus stop is \_\_\_\_\_ the cybercafé.
- sports store / bookstore  
The sports store \_\_\_\_\_.
- movie theater / bookstore  
The \_\_\_\_\_.
- sports store / fast food restaurant / clothes store  
The \_\_\_\_\_.

**3 Where are these people? Find them in the picture and answer the questions.**

- Where is Kathy?  
**Kathy is next to the cybercafé**
- Where are Liz and Ronaldo?  
\_\_\_\_\_
- Where is Anita?  
\_\_\_\_\_
- Where is Chris?  
\_\_\_\_\_
- Where is Maria?  
\_\_\_\_\_
- Where are Sasha and Javier?  
\_\_\_\_\_



**Puzzle** page 55, puzzle 3



**4 Over to you!**

Draw your ideal shopping mall. Ask and answer in class.

- Student A: **Is there a cybercafé?**  
 Student B: **Yes, there is.**  
 Student A: **Where is it?**  
 Student B: **It's next to the sports store.**





# WELCOME TO LOS ANGELES

## THE CITY OF ANGELS!

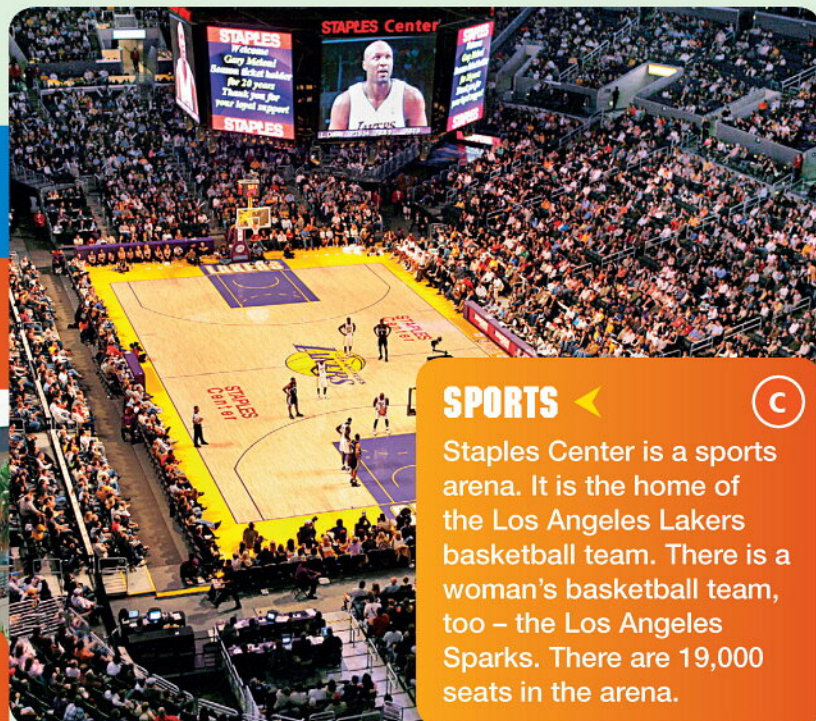

**SPORTS** ◀ (C)

Staples Center is a sports arena. It is the home of the Los Angeles Lakers basketball team. There is a woman's basketball team, too – the Los Angeles Sparks. There are 19,000 seats in the arena.



**SHOPPING** ◀ (A)

Rodeo Drive is four blocks long. It is a famous shopping area between Wilshire Boulevard and Santa Monica Boulevard. There are many luxury clothes stores and expensive restaurants there.



**BEACHES** ◀ (D)

There are a lot of great beaches in L.A., including Malibu Beach and Venice Beach. In fact, in the community of Malibu, there are 34 kilometers of beach. There are swimmers, surfers, and beautiful people there!

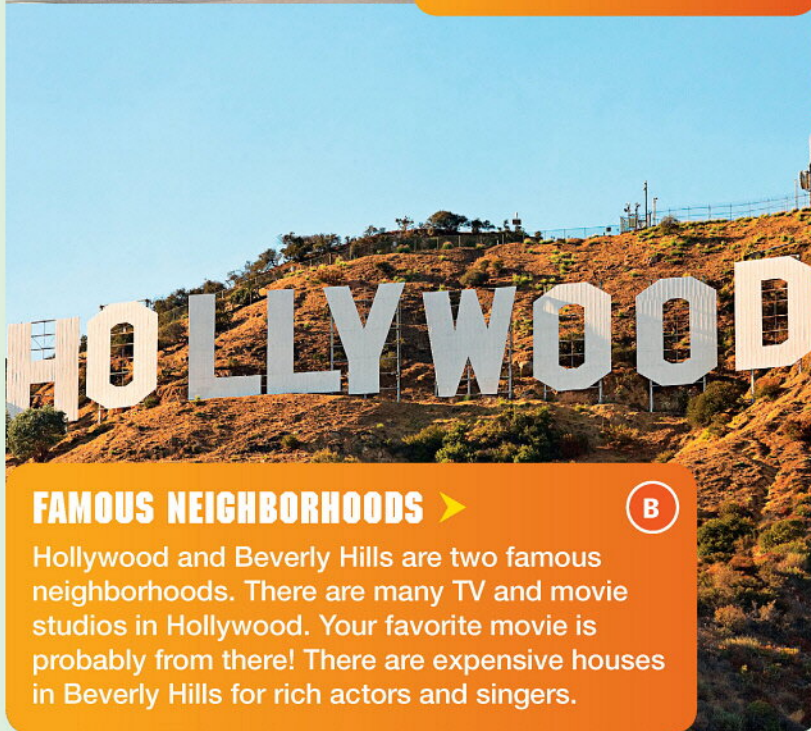

**FAMOUS NEIGHBORHOODS** ▶ (B)

Hollywood and Beverly Hills are two famous neighborhoods. There are many TV and movie studios in Hollywood. Your favorite movie is probably from there! There are expensive houses in Beverly Hills for rich actors and singers.

**3** Read again. Answer the questions.

- Where are famous TV and movie studios?  
In Hollywood
- Where are there houses for famous singers and actors?  
.....
- What is Staples Center?  
.....
- What are the names of two basketball teams?  
.....
- Where are there surfers in Los Angeles?  
.....
- Where is Rodeo Drive?  
.....

**Reading** ◀

**1** Look at the photos and the brochure. Is it about places in...?

- a a country    b a city    c a forest

**2** Read the brochure. Match the places with the numbers.

- |                               |                          |
|-------------------------------|--------------------------|
| 1 Malibu                      | a four blocks            |
| 2 Hollywood and Beverly Hills | b two                    |
| 3 Rodeo Drive                 | c nineteen thousand      |
| 4 Staples Center              | d thirty-four kilometers |



## Listening

### Describing your hometown



1 Listen to the conversation. Circle the correct word.

- 1 Leo's hometown is called Tallville / Smallville.
- 2 It's very small / big.
- 3 Leo's favorite place is a cybercafé / bookstore.
- 4 His house is across from / next to it.

2 Listen again. What is there in Leo's town? Check (✓) or put an X (X) by the places. Write the number if there is more than one.

	✓ or X	number?
movie theater	X	
clothes store		
sports store		
bookstore		
fast food restaurant		
cybercafé		

## Speaking

### Asking for directions

1 Listen and read.



2 Look at the Pronunciation box. Listen to the examples.

**Pronunciation**

**o sounds**

- There are two different "o" sounds.

/ɑ/	/ɔ:/
stop	store

Listen again and repeat.

3 Listen. Put the words in the correct column.

dolphin
fox
from
short
sports
your

/ɑ/	/ɔ:/
dolphin	

4 Practice the dialogue in exercise 1.

5 Now change the words in blue. Write a new dialogue. Then practice the dialogue in class.



# ROUND-UP

## Writing

### A description of a place

1 Look at the Writing skills box.

Writing skills
<b>Capital letters</b> <ul style="list-style-type: none"> <li>• Countries (Brazil)</li> <li>• Cities (New York)</li> <li>• Names of places (Central Park)</li> <li>• Buildings (Empire State Building)</li> </ul>

2 Now read the text and circle the capital letters.



London is a big city in the U.K.

Buckingham Palace, Big Ben, and the Tower of London are famous buildings.

There's a big stadium. It's called Wembley.

There's a big park, too. It's called Hyde Park.

London is cool and fun.

3 Rewrite the sentences with capital letters.

1 I'm from berlin in germany.

.....

2 The eiffel tower in paris is very tall.

.....

4 Choose a special place and fill in the chart.

	Example	Your place
City	London	
Country	the U.K.	
Famous buildings	<ul style="list-style-type: none"> <li>• Buckingham Palace</li> <li>• Big Ben</li> <li>• Tower of London</li> </ul>	
Place 1 Name	stadium Wembley	
Place 2 Name	park Hyde Park	
Description	cool, fun	

5 Write a description of your place. Use the text and chart to help you.

## I can ...

1 Complete the sentences with *there is* / *there are* / *there isn't* / *there aren't*.

In my school there is a restroom.

..... a movie theater.

..... a lot of classrooms.

..... any cybercafés.

I can describe a place.

Yes, I can.  I need more practice.

2 Fill in the blanks with the correct words.

1 The movie theater is a cross from the shopping mall.

2 The sports store is n..... t..... the fast food restaurant.

3 The cybercafé is b..... the bookstore and the clothes store.

4 The bus stop is i..... f..... o..... the school.

I can say where places are.

Yes, I can.  I need more practice.







# B Review

## Vocabulary

### Jobs

1 Look at the pictures. Fill in the blanks with a or an and the correct job.



1 She's a dancer.



2 She's .....



3 He's .....



4 He's .....



5 He's .....



6 She's .....

### Family

2 Look at Victor's family tree. Fill in the blanks with the words below.

brother father grandfather grandmother  
mother sister

(1) grandfather Bruno+Angela (2) .....

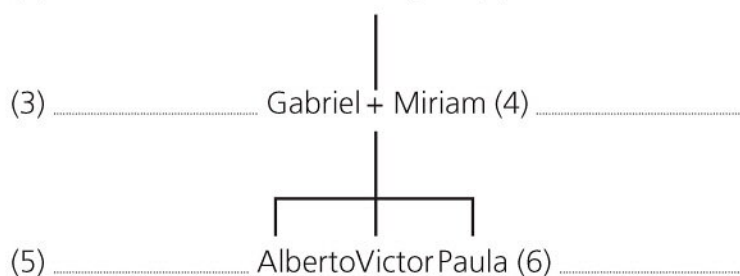

## Nature

3 Unscramble the words. Then write A (Animal) or P (Place).

- 1 ofx fox A
- 2 ridb .....
- 3 irrev .....
- 4 nyokem .....
- 5 hebac .....
- 6 tsrofe .....
- 7 awlrflaet .....
- 8 utbfltrey .....

## Places in a town

4 Label the pictures with the names of the places in a town.



1 cybercafé



2 .....



3 .....



4 .....

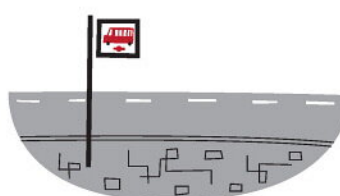

5 .....



6 .....

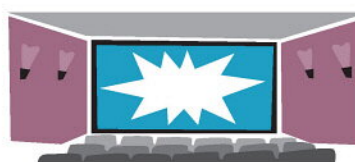

7 .....



8 .....



## Grammar

### be (negative)

- 1** Fill in the blanks with the correct negative form of *be*.

Hi! My name's Ignacio. Ignacio (1) isn't an American name. It's Spanish, but I (2) \_\_\_\_\_ from Spain and my parents (3) \_\_\_\_\_ from Spain. We're from the U.S! Ignacio is my mother's favorite name! My sister's name is Jodie-Lee. Her name (4) \_\_\_\_\_ Spanish. It's American! We're a happy family. We (5) \_\_\_\_\_ sad!

### be (yes / no questions)

- 2** Complete the questions.

- 1 Are you \_\_\_\_\_ from Mexico? Yes, I am.
- 2 \_\_\_\_\_ seventeen? No, she isn't.
- 3 \_\_\_\_\_ happy? Yes, they are.
- 4 \_\_\_\_\_ in the bookstore? Yes, we are.
- 5 \_\_\_\_\_ Japanese? Yes, he is.

### there is / there are

- 3** Look at the picture. Complete the questions and answers.



- 1 Is there \_\_\_\_\_ a bag? Yes, there is \_\_\_\_\_.
- 2 \_\_\_\_\_ an MP3 player? \_\_\_\_\_, \_\_\_\_\_.
- 3 \_\_\_\_\_ a lamp? \_\_\_\_\_, \_\_\_\_\_.
- 4 \_\_\_\_\_ books? \_\_\_\_\_, \_\_\_\_\_.
- 5 \_\_\_\_\_ magazines? \_\_\_\_\_, \_\_\_\_\_.

## Prepositions of place

- 4** Look at the picture. Fill in the blanks with the correct preposition.



- 1 The movie theater is across from \_\_\_\_\_ the shopping mall.
- 2 The cybercafé is \_\_\_\_\_ the movie theater and the bookstore.
- 3 The sports store is \_\_\_\_\_ the bookstore.
- 4 The bus stop is \_\_\_\_\_ the bookstore.
- 5 Amy and her friends are \_\_\_\_\_ the cybercafé.

## Study skills

### Spelling

Make a list of difficult words in your notebook. Practice spelling the words.

- 1** Look at these words from unit 3. Correct the spelling mistakes.

- 1 actor ~~o~~
- 2 riter
- 3 modle
- 4 atlete
- 5 granmother

- 2** Look at pages 46, 47 and 50. Choose five difficult words. Add them to your list and practice spelling them. Ask a friend to help you.



engage

## Magazine B



These are World Heritage Sites. They're special places. They are preserved and protected. There are more than 900 World Heritage sites around the world, in more than 150 countries. There are some countries with many World Heritage sites. For example, Italy has 49. Some are old, and some are new. Look at six of my favorite World Heritage Sites.

1

**Read. Label the pictures with the countries below.**

Australia

The United States

China

India

Peru

Italy



1

The Great Wall:

China

2

The Sydney Opera House:



3

The Statue of Liberty:



4

The Colosseum:



5

Machu Picchu:



6

The Taj Mahal:



2

Look at the pictures. Unscramble the words and write what you can see in each picture.

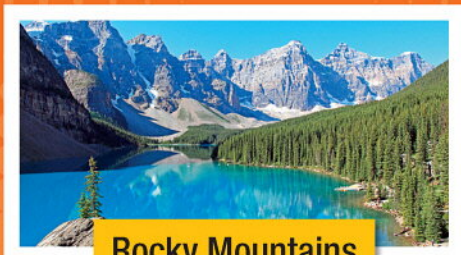

Rocky Mountains Parks (Canada)

nitmnoau

mountain

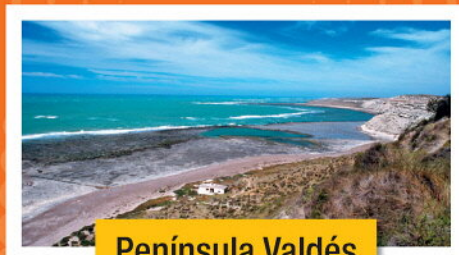

Península Valdés (Argentina)

n c e o a

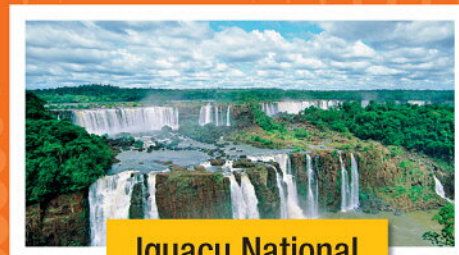

Iguaçu National Park, Brazil

eirrv

v r i r e

a b c e h

a a e f l l r t w

3

Look at the World Heritage Sites on pages 58 and 59. Write C (Cultural) or N (Natural) next to the sites below.

1 The Rocky Mountain Parks

N

2 The Taj Mahal

3 The Great Wall

4 Península Valdés

5 The Statue of Liberty

6 Mount Kilimanjaro

7 Iguaçu National Park

8 Sydney Opera House

World Heritage Sites are cultural or natural.

Some World Heritage sites, like Machu Picchu, are cultural and natural.

4

### Project

There are 19 World Heritage Sites in Brazil. This is the Historic Town of Ouro Preto. It's in Minas Gerais. It is a cultural site. It is old, and beautiful.

- 1 Choose a World Heritage Site from your country. (<http://whc.unesco.org/en/statesparties/>)
- 2 Find a picture of the site or draw or paint it yourself.
- 3 Draw or copy a map of your country and show where the site is.
- 4 Write a text. Answer the questions.
  - What is the name?
  - Where is it?
  - Is it cultural or natural?
  - What is your opinion of the site?



5

Over to you!

Talk about your project to the rest of the class.



# 5

## Fun and games

### Introducing the topic

#### Vocabulary

#### Sports activities

1 Label the photos with the words below. Then listen, check, and repeat.

dance   dive   ice-skate   jump high  
play basketball   ride a horse   run fast  
ski   surf   swim

2 Which of the sports activities are in the Olympic Games? Complete the chart with the verbs in exercise 1.

Summer Olympics	Winter Olympics	Not in the Olympics
run fast		

3 Mime an activity from exercise 1. Can the class guess the verb?

### Puzzle

page 69, puzzle 1



#### OBJECTIVES

- sports activities
- can
- sports verbs
- imperatives
- describing someone's abilities
- talking about abilities
- writing: describing a friend's abilities

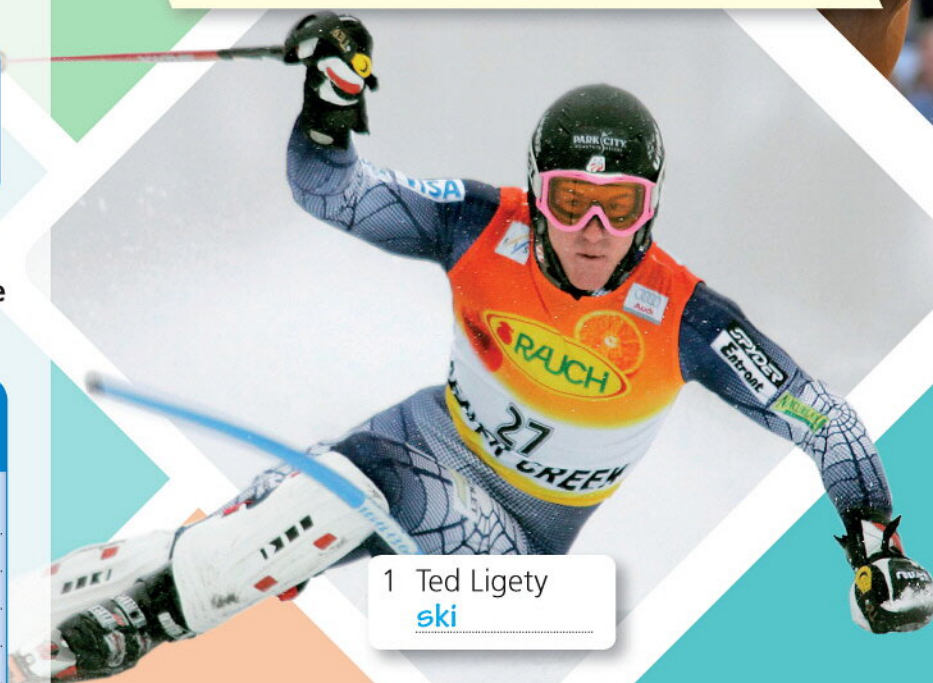

1 Ted Ligety  
ski



2 Yohan Blake



3 Mao Asada





4 Luciana Diniz



5 Svetlana Shkolina



6 Mick Fanning



8 Erika de Souza



10 Joaquín Cortés

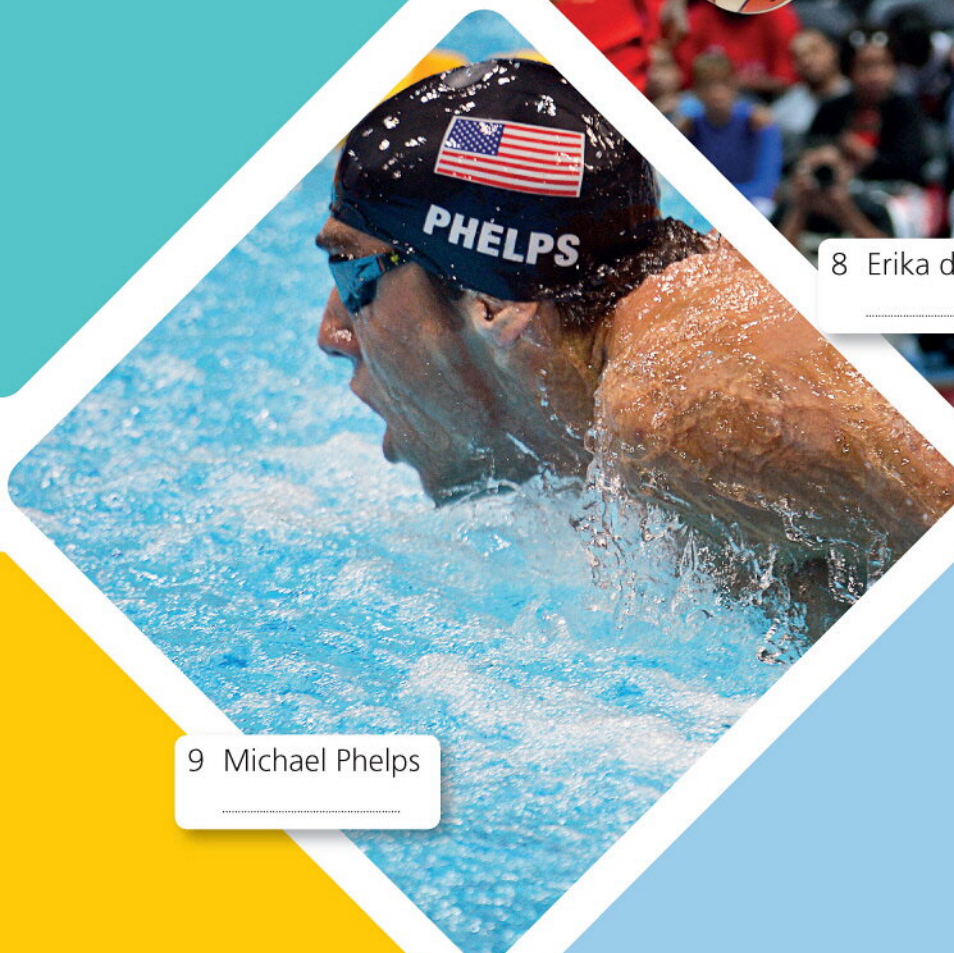

9 Michael Phelps

7 Tom Daley



## Exploring the topic

# International Singing Star

These three young people can all sing. What other things can they do?

**MARA IS FROM SWITZERLAND.** She can ice-skate, ski, and dance. But her favorite sport is surfing! She can surf in the summer when her family goes to the beach. She can't wait for her next vacation.

**PABLO IS FROM ARGENTINA.** He can speak Spanish, German, and English. He can also ride a horse. His horse can run fast and it can jump high. Can Pablo run fast? Yes, he can. But he can't jump high.

**ANTONY IS FROM SOUTH AFRICA.** He can dance and play the piano. He can speak French and English. Can he swim? No, he can't. And he can't surf or dive. He's scared of water.



## Reading

- 1** Read and listen to the article. Match the photos with the names.

- 1 .....  
2 .....  
3 .....

- 2** Read again. Check (✓) or put an X (X) by the questions.

- 1 Can Antony surf?
- 2 Can Pablo run fast?
- 3 Can Pablo and Antony speak English?
- 4 Can Mara surf every day?
- 5 Can Pablo jump high?
- 6 Can Mara dance?

- 3** Read again. Fill in the blanks with *Mara*, *Pablo*, or *Antony*.

- 1 Pablo ..... and Antony ..... can speak other languages.
- 2 ..... 's favorite sport is surfing.
- 3 ..... is from South America.
- 4 ..... isn't happy in the ocean.
- 5 ..... is happy on vacation.
- 6 ..... and ..... are dancers.



# Grammar

## can

Talking about ability

### 1 Look at the chart.

Affirmative		Negative	
I	can run fast.	I	can't run fast.
You	can swim.	You	can't swim.
He / She / It	can jump high.	He / She / It	can't jump high.
We	can dance.	We	can't dance.
You	can ski.	You	can't ski.
They	can ice-skate.	They	can't ice-skate.

### 2 Look at the pictures. Write sentences.

1 ski



2 ice-skate



3 dance



4 run fast



5 ride a horse



6 jump high



- 1 He can't ski .....
- 2 She can .....
- 3 They .....
- 4 .....
- 5 .....
- 6 .....

### 3 Look at the chart.

Questions and short answers		
Can I	swim?	Yes, I <b>can</b> . / No, I <b>can't</b> .
Can you	run fast?	Yes, you <b>can</b> . / No, you <b>can't</b> .
Can he / she / it	dance?	Yes, he / she / it <b>can</b> . / No, he / she / it <b>can't</b> .
Can we	surf?	Yes, we <b>can</b> . / No, we <b>can't</b> .
Can you	ski?	Yes, you <b>can</b> . / No, you <b>can't</b> .
Can they	dive?	Yes, they <b>can</b> . / No, they <b>can't</b> .

### 4 Write questions about Nick, Eva, and Sam.

Name: Nick	can (✓)	can't (X)
swim	✓	
surf	✓	
run fast		X

- 1 Can Nick swim .....
- 2 ..... he .....
- 3 .....

Names: Eva and Sam	can (✓)	can't (X)
ice-skate	✓	
dive		X
jump high	✓	

- 4 ..... Eva and Sam .....
- 5 ..... they .....
- 6 .....

### 5 Write answers to the questions in exercise 4.

- 1 Yes, he can ..... 4 .....
- 2 ..... 5 .....
- 3 ..... 6 .....

## Puzzle

page 69, puzzle 2



### 6 Over to you!

Ask and answer in class with *Can you ...?*  
 Student A: *Can you dance?*  
 Student B: *Yes, I can. / No, I can't.*  
 Tell the class about student B.  
*Nico can dance. He can't ski.*



# Building the topic



## Vocabulary

### Sports verbs

1 Match the photos with the verbs below. Then listen, check, and repeat.

<input checked="" type="checkbox"/> 3 hit	<input type="checkbox"/> kick	<input type="checkbox"/> pass
<input type="checkbox"/> throw	<input type="checkbox"/> touch	<input type="checkbox"/> walk

2 Put the letters in the correct order. Complete the coach's instructions. Then listen and check.

1 ckik



**Kick** \_\_\_\_\_  
the ball!

2 lawk



Run fast! Don't \_\_\_\_\_!

3 ohwtr



\_\_\_\_\_ the ball!

4 saps



\_\_\_\_\_ the ball!

5 ith



Don't \_\_\_\_\_ the coach!

6 otch



\_\_\_\_\_ the ball!



# Grammar

## Imperatives

Giving instructions

1 Look at the chart.

Affirmative	Negative
Run!	Don't run!
Pass the ball!	Don't pass the ball!

2 Look at the pictures. Write the instructions. Use the affirmative (✓) or negative (x).



1 Don't throw the ball!



2 \_\_\_\_\_ the ball!



3 \_\_\_\_\_ the ball!



4 \_\_\_\_\_ the ball!



5 \_\_\_\_\_ fast!

3 Look at the signs. Write the instructions. Use the affirmative or negative.



1 Don't walk \_\_\_\_\_!



2 \_\_\_\_\_!



3 \_\_\_\_\_!



4 \_\_\_\_\_!



5 \_\_\_\_\_!

## Puzzle page 69, puzzle 3



### 4 Over to you!

Find three instructions in this unit.  
Read, ...

Write three instructions for your classroom.  
Use the affirmative or the negative.  
Don't jump on the desks!



# Living English



## EXTREME SPORTS



### A Powerbocking

This sport is from Germany. You can run fast – 32 kilometers per hour! And you can jump high – 2.6 meters high. You can go very high because you have special metal ‘shoes’ and they push you. Frank Dessler is American and he can jump over cars.

### B Freerunning

Freerunning is a sport from France. Daniel Ilabaca is from England and his freerunning videos are very popular, with 30 million views on YouTube. He is a champion freerunner and he can run and jump all over his city.

### C White-water rafting

This sport is popular all over the world. On a slow river, the raft can go 6.5 kilometers per hour and on a fast river, it can go 11 kilometers per hour. Four to twelve people can go on a raft. It’s sometimes dangerous, but it’s fun!

### D Wave skiing

This sport is from the United States. It’s a small sport, with only 10,000 participants around the world. In this sport, you can’t stand up. You can only sit. But you can jump high and dive. What’s the best part? You’re at the beach!

## Reading

1 Look at the photos and read the profiles. Match the photos with the profiles.

1 D 2 \_\_\_\_\_ 3 \_\_\_\_\_ 4 \_\_\_\_\_

2 Read again. Correct the information in blue.

1 Four to twelve people can go on a **wave ski**.  
*Four to twelve people can go on a raft.*

2 Frank Dessler can jump over **trucks**.

3 Freerunning is from **the U.S.**

4 Daniel Ilabaca is a champion **powerbocker**.

5 Wave skiing is a **big** sport.

6 A raft can go **32** kilometers per hour.

7 In this sport, you can only **stand up**.

8 Frank Dessler is **German**.

**Puzzle**

page 69, puzzle 4





### Listening

#### Describing someone's abilities

1 Listen. Who is Katy? .....



2 Listen again. What can Katy do? Check (✓) or put an X (X) by the activities.

	Katy can / can't
run fast	✓
swim fast	
ride a bike fast	
sing	
ride a horse	
play basketball	

3 Listen again. Complete the sentences.

- Katy is Rob's sister.
- She can run five kilometers in ..... minutes.
- There are ..... activities in a triathlon.
- Katy is a triathlon .....

### Speaking

#### Talking about abilities

1 Listen and read.



2 Look at the Pronunciation box. Listen to the examples.

**Pronunciation**

**can**

- In the affirmative and questions, we pronounce *can* as /kən/.
- In short answers, we pronounce *can* as /kæn/.

Can you jump high?	Yes, I can.
I can dance.	

Listen again and repeat.

3 Listen. Check (✓) the correct column.

	/kən/	/kæn/
1 Can you ride a bike?	✓	
2 I can ski.		
3 Yes, I can.		
4 Can you ski?		

4 Practice the dialogue in exercise 1.

5 Now change the words in blue. Write a new dialogue. Then practice the dialogue in class.



# ROUND-UP

## Writing

### Describing friends' abilities

1 Look at the Writing skills box.

**Writing skills**

*and and but*

- We use **and** to join similar ideas.  
I can swim **and** I can ride a bike.
- We use **but** to join contrasting ideas.  
I can swim, **but** I can't ride a bike.

2 Now read the text. Circle the examples of *and* and *but*.

My name's Julia. I can swim, but I can't ice-skate.

My friends are Tom and Sarah. Tom can run fast and he can jump high. He's awesome! Sarah can dance, but she can't ice-skate. She's great!



3 Fill in the chart with information about Julia and her friends.

Name	can	can't
Julia	swim	ice-skate
Tom	.....	.....
Sarah	.....	.....
you		
your friend		
your friend		

4 Now fill in the chart with information about you and your friends.

5 Write about you and your friends. Use the text and the chart to help you.

## I can ...

1 Answer the questions with *can* / *can't*.

- Can you run fast? Yes, **I can**
- Can you play basketball? No, .....
- Can you ski? Yes, .....
- Can you play soccer? No, .....

I can talk about what I can and can't do.

Yes, I can.  I need more practice.

2 Match the sentence halves.

- |              |                          |
|--------------|--------------------------|
| 1 Kick       | a when the light is red. |
| 2 Run        | b in the lake!           |
| 3 Don't walk | c fast!                  |
| 4 Don't swim | d the ball!              |

I can give instructions.

Yes, I can.  I need more practice.



# puzzle 1

READ THE LETTERS AND FOLLOW THE CODE. USE THE CODE AND WRITE THE SPORTS ACTIVITIES.

K	L	M	N	O	P	Q
A	B	C	D	E	F	G
R	S	T	U	V	W	X
H	I	J	K	L	M	N
Y	Z	A	B	C	D	E
O	P	Q	R	S	T	U
F	G	H	I	J		
V	W	X	Y	Z		

- NSFO DIVE \_\_\_\_\_
- CEBP \_\_\_\_\_
- SMD-CUKDO \_\_\_\_\_
- CGSW \_\_\_\_\_
- BSNOK RYBCO \_\_\_\_\_
- AVKI LACUODLKUU \_\_\_\_\_
- TEWZ RSQR \_\_\_\_\_
- NKXMO \_\_\_\_\_

# puzzle 2

Use the words with the same color. Order the words to make sentences.

<b>FAST</b>	<b>CAN</b>
<b>SKI</b>	<b>CAN'T</b>
<b>SOCCER</b>	<b>TEACHER</b>
<b>FRIENDS</b>	<b>RUN</b>
<b>PLAY</b>	<b>CAN'T</b>
<b>+</b>	<b>MY</b>
<b>MY</b>	<b>I</b>
<b>DANCE</b>	<b>CAN</b>

*I can run fast*  
 \_\_\_\_\_  
 \_\_\_\_\_  
 \_\_\_\_\_

Are the sentences true for you?

# puzzle 3

Find and circle six verbs. Then write them next to the correct picture.

H	I	I	C	K
T	T	K	W	W
O	U	R	O	A
H	C	H	T	L
P	A	S	S	K

- 1 
- 2 
- 3 
- 4 
- 5 
- 6 

- HIT \_\_\_\_\_
- \_\_\_\_\_
- \_\_\_\_\_
- \_\_\_\_\_
- \_\_\_\_\_
- \_\_\_\_\_

# puzzle 4

Look at the letter code. Write four sentences.

A	B	C	D	E	F	G
Y	Z	A	B	C	D	E
H	I	J	K	L	M	N
F	G	H	I	J	K	L
O	P	Q	R	S	T	U
M	N	O	P	Q	R	S
V	W	X	Y	Z		
T	U	V	W	X		

- ▶ VJTQY VJG DCNN.
- ▶ FQP'V MKEM KV!
- ▶ RCUU KV.
- ▶ TWP HCUV YKVJ VJG DCNN!

*Throw the ball*  
 \_\_\_\_\_  
 \_\_\_\_\_  
 \_\_\_\_\_  
 \_\_\_\_\_  
 \_\_\_\_\_  
 \_\_\_\_\_

What's the secret sport?  
 \_\_\_\_\_



# 6

## Work and play

### Introducing the topic

#### Vocabulary

#### Daily routines

1 Label the pictures with the words below. Then listen, check, and repeat.

do my homework   finish classes   ~~get up~~  
 go to bed   go to school   have breakfast  
 have dinner   have lunch   start classes  
 watch TV

#### Take note!

*at / in*

at seven thirty / nine o'clock

in the morning / afternoon / evening

2 Complete the sentences with *at* or *in*, and a time expression.

1 I get up .....

2 I start classes .....

3 I do my homework .....

4 I go to bed .....

#### OBJECTIVES

- daily routines
- simple present (affirmative)
- school subjects
- daily routines
- talking about school subjects
- writing: an e-mail about your day



### Puzzle page 79, puzzle 1

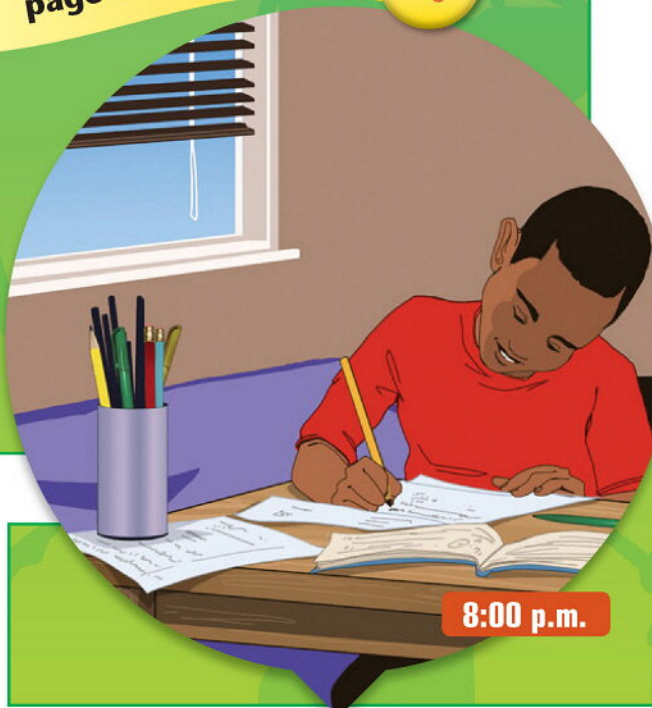

7

8



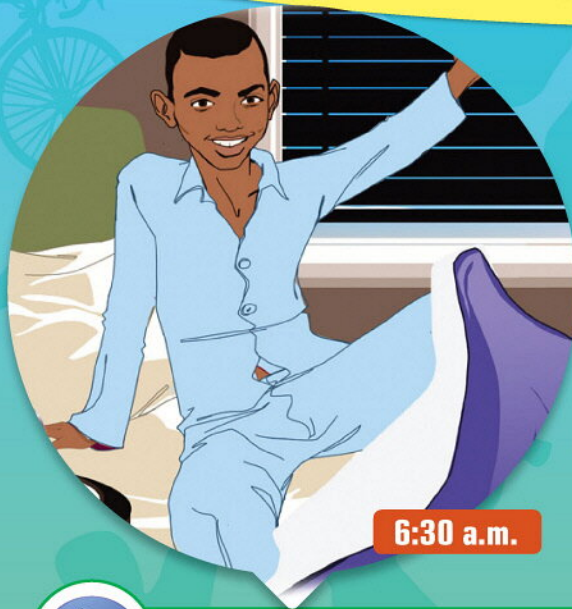

6:30 a.m.



7:00 a.m.



7:30 a.m.



1 *get up*

2

3



1:00 p.m.



8:00 a.m.

5

4



9:00 p.m.



10:00 p.m.

9

10



## Exploring the topic

Different countries,  
different lives

My profile



**BASIC INFORMATION**

**About me**

My name is Hyun. I'm from Seoul in South Korea. I get up at six thirty and I go to school at seven thirty. We start classes at eight o'clock and finish at four o'clock. We have lunch at twelve o'clock. After school, I do my homework and I have dinner with my family. I watch TV, and then I go to bed at eleven o'clock.

On Saturdays, I go to school. I start classes at eight o'clock and finish at twelve o'clock. I play computer games with my friends in the afternoon.

My profile



**BASIC INFORMATION**

**About me**

I'm Adriana from Rio de Janeiro in Brazil. I get up at eight o'clock. I do my homework in the morning. Then I have lunch at twelve o'clock and I go to school. My classes start at one o'clock in the afternoon and finish at five thirty. My friends and I play volleyball in the evening, and I go to bed at ten thirty. On Saturdays, I go to the beach with my friends.

## Reading

1  Read and listen to the profiles. Where are Hyun and Adriana from?

2 Read again. Fill in the blanks in the chart.

	Hyun	Adriana
get up	(1) 6:30 a.m.	8:00 a.m.
start classes	(2) .....	(3) .....
finish classes	4:00 p.m.	(4) .....
go to bed	(5) .....	(6) .....

3 Read again. Write H (Hyun), A (Adriana), or B (both).

- "I do my homework in the morning." A
- "In the afternoon, I play computer games." .....
- "After school, I have dinner with my family." .....
- "I have lunch at twelve o'clock." .....
- "I play volleyball in the evening." .....
- "I go to school on Saturdays." .....



## Grammar

## Simple present (affirmative)

Talking about daily activities

## 1 Look at the chart.

Affirmative		
I	go to school	at eight o'clock.
You	get up	at seven thirty.
We	have lunch	at twelve thirty.
You	watch TV	in the evening.
They	finish classes	at three o'clock.

## 2 Look at the pictures. Complete the sentences.

1 We **get up** ..... at seven o'clock.

2 We ..... at seven thirty.



3 We ..... at eight o'clock.



4 I ..... at eight o'clock.



5 I ..... at eight o'clock.



6 We ..... at ten o'clock.

## 3 Fill in the blanks with the correct verbs.

In the morning, I (1) **get** ..... up at seven thirty. Then I (2) ..... breakfast. I (3) ..... to school with my sisters. We (4) ..... classes at nine o'clock and (5) ..... classes at three thirty. After school, I (6) ..... TV, but my sisters (7) ..... their homework. We (8) ..... dinner at seven thirty, and I (9) ..... to bed at ten thirty.

## Puzzle page 79, puzzle 2



## 4 Over to you!

Write three true sentences and one false sentence about your daily routine. Can the class guess the false sentence?

Student A: I get up at eight o'clock.

Student B: True! / False!



# Building the topic

## Vocabulary

### School subjects

1 Look at the pictures. Fill in the blanks with the words below. Then listen, check, and repeat.

art computer science English geography  
 history math music P.E. science  
 technology

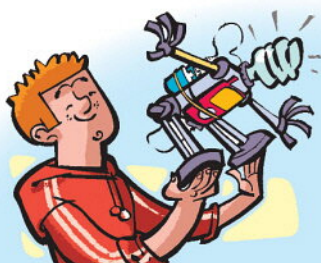

3 His favorite subject is .....

4 She studies ..... in the evening.



7 He thinks ..... is interesting.

8 She studies ..... on a PC.



1 He thinks science is cool.



2 She has ..... at two thirty.



5 He has ..... in Room 3.



6 She goes to an ..... club after school.



9 His ..... class finishes at twelve o'clock.

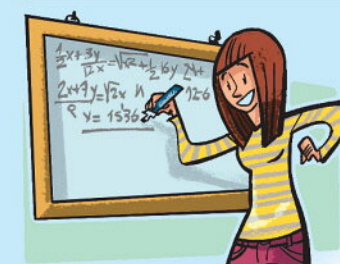

10 Her favorite subject is .....

2 Fill in the subjects in Marta's schedule.

TUESDAY	
9:00-10:00	
(1) <u>geography</u>	
10:00-11:00	
(2) .....	
11:00-12:00	
(3) .....	
LUNCH	
1:00-2:00	
(4) .....	
2:00-3:00	$x + y = 33$ $\frac{z}{}$
(5) .....	

### Take note!

#### Capital letters

- Languages: *English, Portuguese*
- Abbreviations: *P.E.* (physical education), *PC* (personal computer)

3 Fill in your schedule for today.

Day: .....	
Time	Subject
.....	.....
.....	.....
.....	.....
.....	.....
.....	.....
.....	.....



## Work and play

6

### Grammar

#### Simple present (he / she / it)

Talking about daily activities

#### 1 Look at the chart.

<b>Affirmative</b>
<b>add -s</b>
He <b>thinks</b> science is cool.
She <b>likes</b> math.
It <b>starts</b> at 9 o'clock.
<b>add -es after -o, -x, -sh, or -ch</b>
He <b>goes</b> to school on Saturdays.
She <b>does</b> her homework in the morning.
It <b>finishes</b> at nine thirty.
<b>change -y to -i and add -es</b>
He / She / It <b>studies</b> English.
<b>irregular</b>
He / She / It <b>has</b> breakfast in the morning.

#### 2 Fill in the blanks with the correct form of the verb in parentheses.

- 1 My brother gets up at six thirty. (get)
- 2 The science class \_\_\_\_\_ at eleven thirty. (start)
- 3 She \_\_\_\_\_ to school. (walk)
- 4 School \_\_\_\_\_ at four o'clock. (finish)
- 5 Julia \_\_\_\_\_ two math classes today. (have)
- 6 He \_\_\_\_\_ to the cybercafé on Mondays. (go)

#### 3 Look at the pictures. Fill in the blanks with the correct form of the verbs below.

do go jump play study watch



1 Jack plays soccer in P.E.



2 My sister \_\_\_\_\_ TV in the morning.

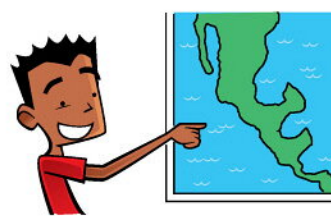

3 He \_\_\_\_\_ high geography at school.



4 Lucia \_\_\_\_\_ in basketball.



5 Carlos \_\_\_\_\_ his homework at 7 p.m.



6 She \_\_\_\_\_ to art club after school.

#### 4 Look at Jed's daily activities. Write a sentence for each day.

MONDAY	walk to school with Marcus
TUESDAY	go to computer club
WEDNESDAY	watch a soccer game at school
THURSDAY	have dinner with my grandparents
FRIDAY	play computer games at the cybercafé

- 1 On Mondays, Jed walks to school with Marcus
- 2 On Tuesdays, he \_\_\_\_\_
- 3 \_\_\_\_\_
- 4 \_\_\_\_\_
- 5 \_\_\_\_\_

### Puzzle page 79, puzzle 4

#### 5 Over to you!

Choose three days. Write a daily activity for each day.

*On Saturdays, I play basketball.*

Exchange your sentences in class. Tell the class about another student.

*On Saturdays, Umberto does his homework.*



# An extraordinary teenager



ISAAC BEECH is fourteen years old. His nickname is Zac. He goes to a special school in Manchester in the U.K. It's called Chetham's, and it's a famous music school. Zac plays the piano and the violin. He's very good. Zac studies regular subjects like English, science, and math at the school, but he has music classes every day, too.

Some students go home when they finish class at Chetham's, but Zac can't. His parents and two sisters are in Bristol, 220 kilometers from Manchester. So Chetham's is Zac's school and his home. He studies there, he has breakfast, lunch, and dinner there, and he goes to bed there. There are three other boys in Zac's room at school. He thinks it's fun.

On Saturday mornings, Zac gets up and goes to school. There aren't classes, but he plays the violin in the school orchestra. He has free time in the afternoon. On Sundays, Zac does his homework and plays sports. In the evenings, he watches TV and uses the computer. He has two hundred cyber friends!



## Reading

**1** Look at the Reading skills box.

### Reading skills

#### Predicting what a text is about

- Look at the title and the pictures before reading. Try to form an idea of what the text is about.

Look at the title and the pictures. Circle the correct options in the summary.

The text is about a (1) girl / boy who is aged between (2) 13 and 19 / 8 and 12 years old. This person is a (3) musician / soccer player and goes to a (4) regular / special school.

Now read the article quickly. Were you correct?

**2** Read again. Fill in the information.

NAME:	1	Isaac Beech
NICKNAME:	2	.....
AGE:	3	.....
HOMETOWN:	4	.....
NAME OF SCHOOL:	5	.....
LOCATION:	6	.....

**3** Read again. Circle T (True) or F (False).

- Zac can play two musical instruments.  T /  F
- He studies music on Saturdays.  T /  F
- Zac's bedroom is in his school.  T /  F
- There's one bed in his room.  T /  F
- Zac goes home on the weekends.  T /  F
- He has a lot of friends on the Internet.  T /  F



## Listening

### Describing your daily routine



1 Listen. Where is Cristina from? Where is she right now?

2 Listen again. Check (✓) the correct column(s).

	In Spain	In the U.S.
1 She gets up at seven thirty.		✓
2 She has lunch at two o'clock.		
3 She goes to clothes stores after school.		
4 She gets up at ten thirty on Saturdays and Sundays.		
5 She goes to the beach on Saturdays and Sundays.		

## Speaking

### Talking about school subjects

1 Listen and read.

Tell me about your sister, Becky.

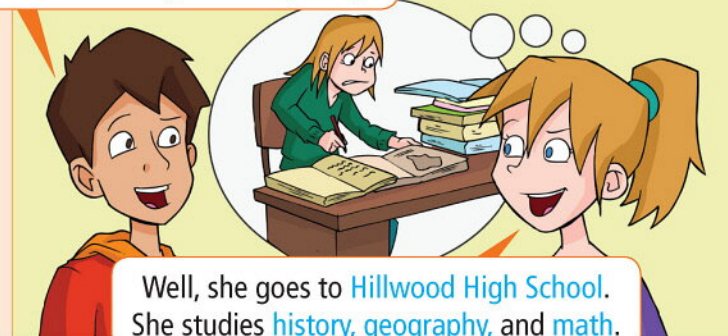

And she studies art. She wants to be an artist.



2 Look at the Pronunciation box. Listen to the examples.

### Pronunciation

#### Simple present -s

- The pronunciation of simple present -s is different for different verbs.

/s/	/z/	/ɪz/
wants	goes	watches

Listen again and repeat.

3 Listen. Put the verbs in the correct column.

does finishes gets rides thinks

/s/	/z/	/ɪz/
gets		

4 Practice the dialogue in exercise 1.

5 Now change the words in blue. Write a new dialogue. Then practice the dialogue in class.



# ROUND-UP

## Writing

### An e-mail about your day

1 Look at the Writing skills box.

**Writing skills**

*then*

- We use *then* for sequences.

I get up at seven o'clock. **Then** I have breakfast.  
 I get up at seven o'clock, and **then** I have breakfast.

2 Read the e-mail. Circle the examples of *then*.

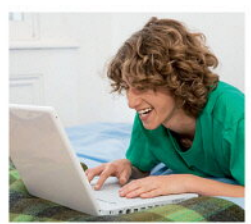
Dear Carlos,

How are you?  
 This is my day. In the morning, I get up at seven o'clock and I have breakfast. Then I go to school. I start classes at eight o'clock. I have lunch at twelve o'clock. In the afternoon, I finish classes at two thirty. Then my friends and I play soccer or we play computer games. In the evening, I have dinner at six thirty. I do my homework, and then I go to bed. What about you?  
 Write soon,  
 Damon

3 Fill in the chart with information about Damon's day.

	Damon's day	Your day
In the morning	get up at seven o'clock	
	have breakfast	
	.....	
	.....	
In the afternoon	.....	
	.....	
	.....	
	.....	
In the evening	.....	
	.....	
	.....	
	.....	

4 Now fill in the chart with information about your day.

5 Write an e-mail about your day. Use the text and the chart to help you.

## I can ...

1 Unscramble the words to make sentences.

- 1 o'clock / at / get up / seven / They  
They get up at seven o'clock .....
- 2 classes / eight / We / at / thirty / start  
 .....
- 3 his / school / after / does / He / homework  
 .....
- 4 thirty / has / She / at / seven / dinner  
 .....

**I can talk about daily activities.**

Yes, I can.  I need more practice.

2 Write four sentences about your weekend.

- 1 I get up at nine o'clock .....
- 2 .....
- 3 .....
- 4 .....

**I can describe my routine.**

Yes, I can.  I need more practice.







# C

# Review

## Vocabulary

### Sports activities

1 Label the pictures with the sports activities.



1 jump high



2 \_\_\_\_\_



3 \_\_\_\_\_



4 \_\_\_\_\_



5 \_\_\_\_\_



6 \_\_\_\_\_



7 \_\_\_\_\_



8 \_\_\_\_\_



9 \_\_\_\_\_



10 \_\_\_\_\_

## Sports verbs

2 Unscramble the verbs.

- 1 s p s a    pass
- 2 i t h    \_\_\_\_\_
- 3 k k i c    \_\_\_\_\_
- 4 h w o t r    \_\_\_\_\_
- 5 u h o t c    \_\_\_\_\_
- 6 l w k a    \_\_\_\_\_

## Daily routines

3 Fill in the blanks in the sentences with the words below.

do   finish   get up   go   have   start   watch

- 1 We start classes at eight thirty in the morning and \_\_\_\_\_ classes at three thirty in the afternoon.
- 2 After school, I \_\_\_\_\_ my homework and then I \_\_\_\_\_ TV.
- 3 I \_\_\_\_\_ at seven thirty in the morning and then I \_\_\_\_\_ breakfast.
- 4 On the weekend, I \_\_\_\_\_ to bed late.

## School subjects

4 Find nine school subjects in the word snake.





## Grammar

### can

#### 1 Complete the dialogues.

- 1 A: Can you ski (you / ski), Ben?  
 B: No, I ..... . But I .....  
 (ice-skate).
- 2 A: .....  
 (Lucas and Ivan / run) fast?  
 B: Yes, they ..... . But they .....  
 ..... (jump) high.
- 3 A: .....  
 (your father / swim) a kilometer?  
 B: No, he ..... . But he .....  
 (dive) 10 meters!
- 4 A: ..... (you / kick) the ball?  
 B: Yes, I ..... . And I .....  
 (throw) it. Watch!

### Imperatives

#### 2 Look at the signs. Write imperatives. Use the words below.

kick balls    ~~play music~~    ride bikes    swim  
 throw trash here    walk with your dog



1 Don't play music !



2 .....  
 .....



3 .....  
 .....



4 .....  
 .....



5 .....  
 .....



6 .....  
 .....

### Simple present (affirmative)

#### 3 Fill in the blanks with the correct form of the verbs below.

have    go    play    ride    study    watch

- 1 On Saturdays, my sister and her friends  
go to the shopping mall.
- 2 My brother ..... lunch in a cybercafé.
- 3 We ..... TV in the evenings.
- 4 I ..... my bike to school every day.
- 5 Emma ..... Spanish and Portuguese.
- 6 My brother and I ..... soccer on the weekends.

### Study skills

#### Recording grammar

Make a grammar section in your notebook. Write translations, and explanations in your language. Write examples of your mistakes.

#### 1 Look at the notes.

+s He ~~get~~up at 8:00.  
 +es She ~~watch~~s TV.  
 y +ies Jack ~~studie~~s history.  
 She ~~start~~ school at 9 o'clock. X  
 She ~~start~~s school at 9 o'clock. ✓

What is the grammar point?

- a be  
 b simple present (all forms)  
 c simple present (he / she / it)

#### 2 Make notes on the simple present in your notebook.



# engage

# Magazine C



**1**

Look at the pictures.  
Complete the words.



**1** d e s e r t

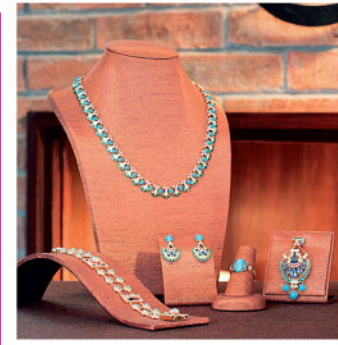

**2** j \_ \_ \_ \_ y



**3** t \_ \_ b



**4** s \_ \_ \_ \_ e



**5** p \_ \_ \_ \_ \_ d



**6** k \_ \_ g

**2**

Read and use four words from  
exercise 1 to complete the text.



My name is  
Tutankhamun, or King  
Tut. I'm from Egypt.  
I'm a  
1 king from  
5000 years ago.

There's an important  
river in Egypt, the Nile  
River. Most Egyptians  
live near the Nile. It's  
very long.

The Nile is  
important, but most  
of Egypt is a  
2 \_\_\_\_\_ ,  
too. It's hot.

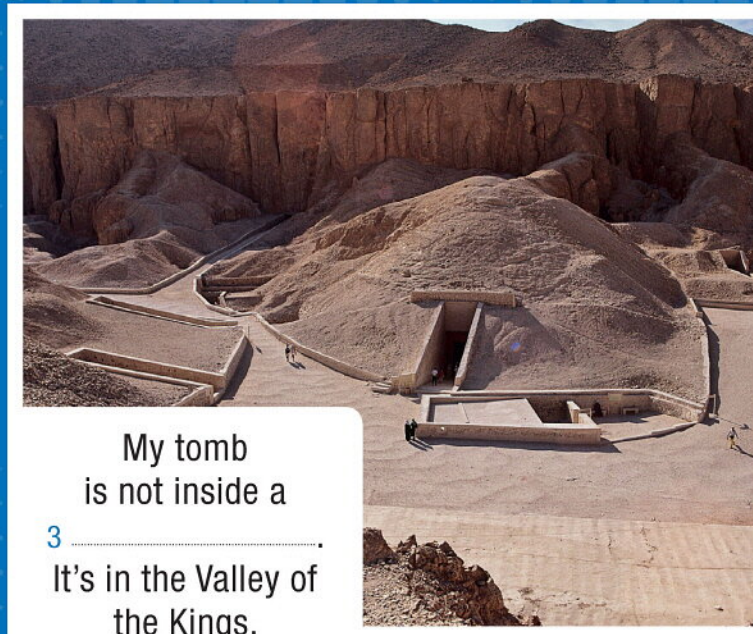

My tomb  
is not inside a  
3 \_\_\_\_\_ .  
It's in the Valley of  
the Kings.



# 3

There are lot of interesting monuments for famous people. Match these famous monuments to their names and places.

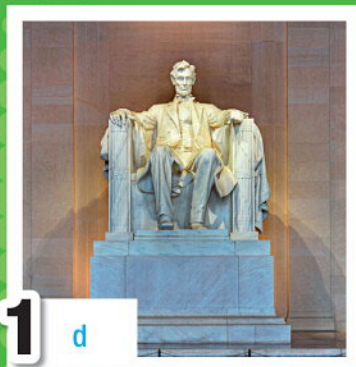

1 d



2



3



4

**a** Joan of Arc, Paris, France

**b** The Great Pyramid of Giza, Cairo, Egypt

**c** Tiradentes Square, Ouro Preto, Brazil

**d** The Lincoln Memorial, Washington, D.C., the United States

You can visit my tomb. There are many interesting things inside.

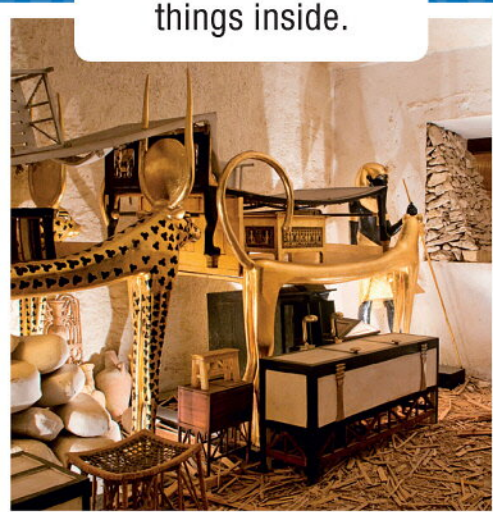

And, you can see me.

You can see chairs, beds, 4 \_\_\_\_\_, statues, and shoes.



# 4

**Over to you!**

Talk about these questions.

- 1 What kinds of people have big or famous monuments?
- 2 Are there any famous monuments in your city, your state, or your country?
- 3 Who is a famous person from your country's history? Where is his / her tomb or monument?

# 5

**Project**

This is Napoleon Bonaparte. His date of birth is 1769. He's French and he is from Corsica. He's a famous French general. His big monument or tomb is in Paris, France.



- Choose a famous person from history.
- Research this person's life and his / her tomb.
- Find a picture of this person. If you want, wear a hat, coat, or other item to look like this person.
- Tell your class who you are.



## 7

## This is me

## OBJECTIVES

- preferences
- simple present (negative and yes / no questions)
- clothes
- imperatives
- describing your favorite sports team
- talking about habits
- writing: my preferences

## Introducing the topic

## Vocabulary

## Preferences

- 1  Look at the pictures. Fill in the blanks with the words below. Then listen, check, and repeat.

eat hate like listen live love read  
speak wear

- 2 Unscramble the letters to make the verbs. Then write the sentences.

1 I VOLE Tokyo.

I love Tokyo

2 I don't AWRE T-shirts with slogans.

3 I EATH Mondays.

4 We don't TAE hamburgers.

5 I TILES N to rock music.

6 I don't KEASP in the mornings.

7 We KELI Katy Perry.

8 I VLIE in Quito.

9 We DERA music magazines.

- 3 What are your preferences? Circle the verbs.

- 1 I eat / don't eat meat.
- 2 I wear / don't wear sneakers.
- 3 I listen / don't listen to hip-hop.
- 4 I like / don't like soccer.

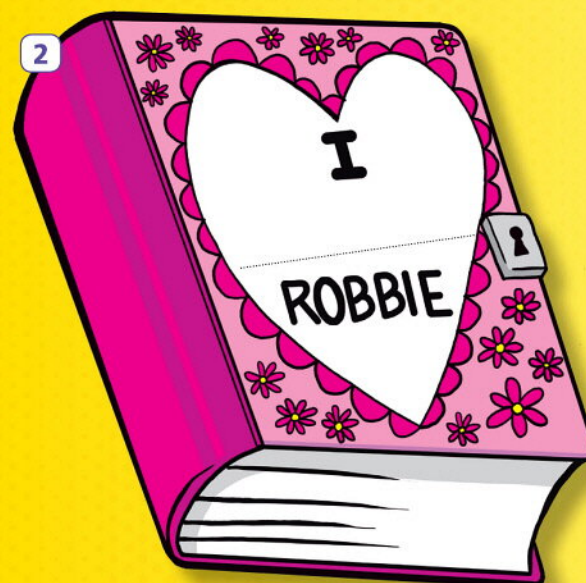
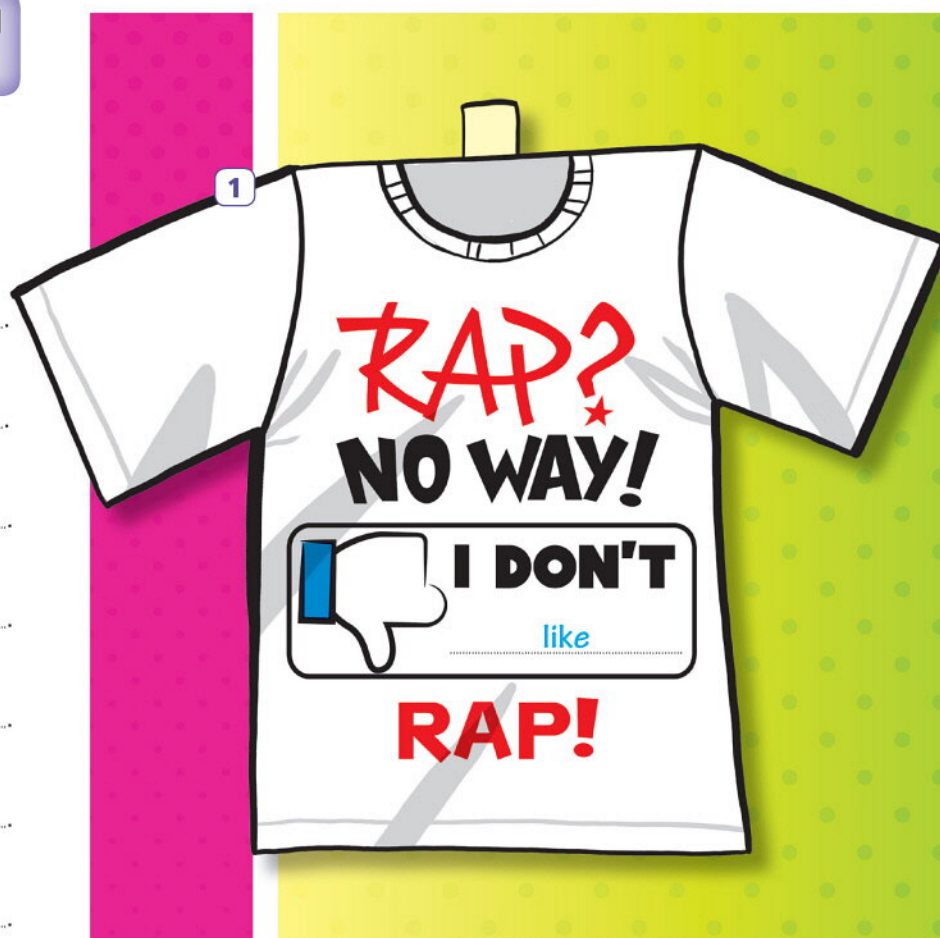

Puzzle page 93, puzzle 1





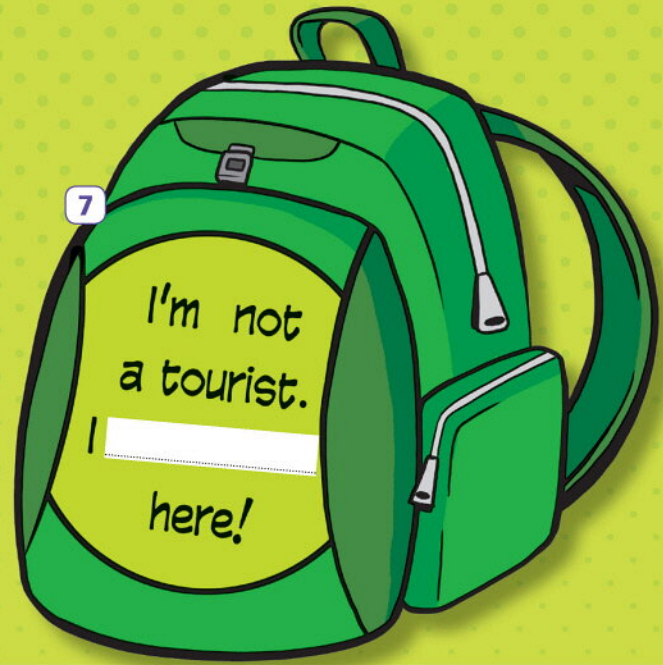
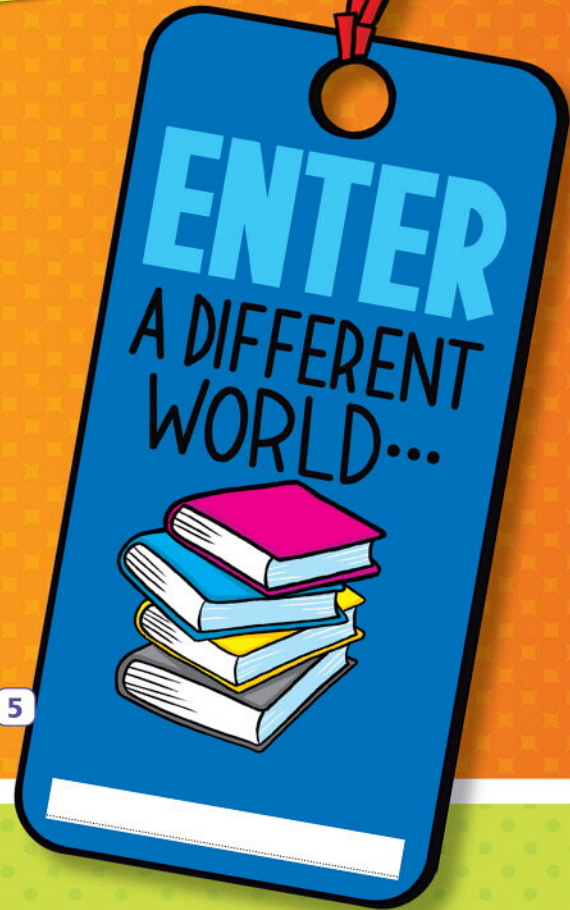
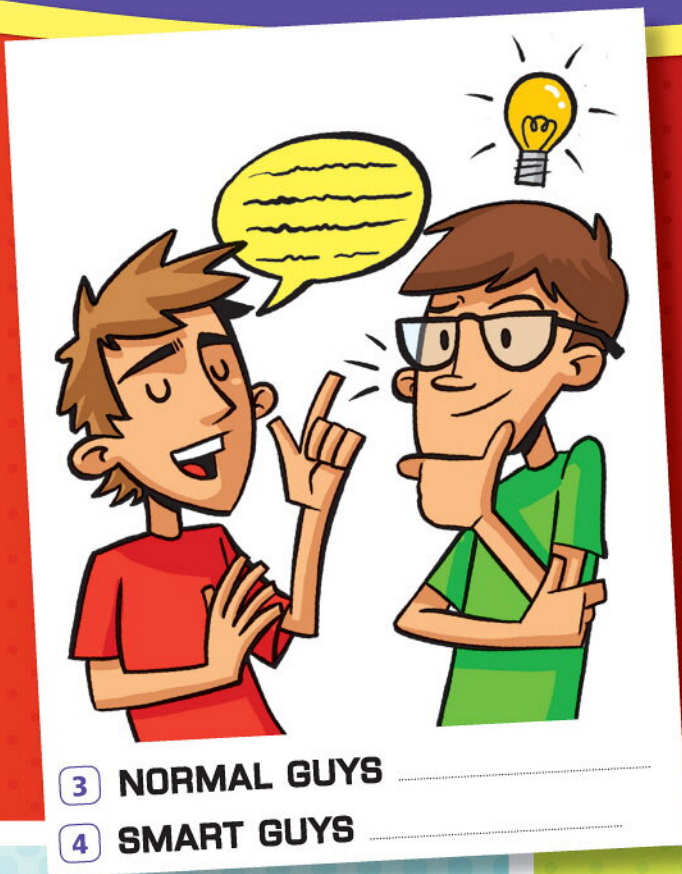



## Exploring the topic

### ALL ABOUT ME



My name's Bradley and I'm fourteen. I'm from California, but I live in Palm Beach in Australia. It's one hour from Sydney. I'm a student at Currumbin High School in Palm Beach. I love science and music, but I hate geography and math. My favorite subject is P.E. I can run fast. I play basketball and I surf, but I don't surf at school! I surf in the afternoons after school and on weekends.

I like hip-hop and rock music. My dad doesn't like my music, so I listen to it in my room. I love *The GazzettE*, a Japanese band. I speak some Japanese, but I don't understand the words when they sing in Japanese! I watch movies, but I don't watch TV. I love Jennifer Lawrence, the American actor. She's in my favorite movie, *The Hunger Games*. I read science fiction books, but I don't read magazines. I wear T-shirts, but I don't wear T-shirts with slogans. I hate them! They aren't cool.

### Reading

1 Look at Bradley's room. What do you know about his preferences? Check (✓) the sentences.

- |                                   |                                     |
|-----------------------------------|-------------------------------------|
| 1 He surfs.                       | <input checked="" type="checkbox"/> |
| 2 He speaks Japanese.             | <input type="checkbox"/>            |
| 3 He eats fast food.              | <input type="checkbox"/>            |
| 4 He loves sports.                | <input type="checkbox"/>            |
| 5 He wears T-shirts with slogans. | <input type="checkbox"/>            |
| 6 He listens to music.            | <input type="checkbox"/>            |
| 7 He likes movies.                | <input type="checkbox"/>            |
| 8 He reads magazines.             | <input type="checkbox"/>            |

Now read and listen to the blog.  
Are your answers correct?

2 Read again. Correct the information in blue.

- Bradley is **American**.  
Bradley is Australian
- He hates **science** and **music**.  
.....
- He **plays basketball** after school.  
.....
- He listens to music **at school**.  
.....
- He reads **romance** books.  
.....
- He **loves** T-shirts with slogans.  
.....



3 Answer the questions.

- Where is Bradley's school?  
**In Palm Beach**
- What's his favorite school subject?  
.....
- What is *The GazzettE*?  
.....
- What is Bradley's favorite movie?  
.....
- Who is in the movie?  
.....
- What is Bradley's opinion of T-shirts with slogans?  
.....



# Grammar

## Simple present (negative)

Talking about facts and habits in the present

### 1 Look at the chart.

Affirmative	Negative
I <b>love</b> chocolate.	I <b>don't love</b> chocolate.
You <b>speak</b> English.	You <b>don't speak</b> English.
He / She / It <b>eats</b> hamburgers.	He / She / It <b>doesn't eat</b> hamburgers.
We <b>read</b> magazines.	We <b>don't read</b> magazines.
You <b>listen</b> to music.	You <b>don't listen</b> to music.
They <b>wear</b> T-shirts.	They <b>don't wear</b> T-shirts.

### 2 Circle the correct option.

- I don't / doesn't like dolphins.
- Jack don't / doesn't speak three languages.
- We don't / doesn't wear school uniforms.
- My father don't / doesn't listen to my music.
- Kate's mother don't / doesn't read books.
- They don't / doesn't eat chocolate.

### 3 Complete the sentences. Use the negative.

- I don't eat ..... meat. I eat fish.
- My friends ..... Japanese. They speak English.
- Gemma ..... drama. She likes art.
- My father ..... magazines. He reads newspapers.
- My teacher ..... to rap music. He listens to hip-hop music.
- We ..... basketball. We play soccer.

### 4 Complete the sentences about the T-shirts. Use the affirmative or negative of the verbs below.

eat listen to love play read watch

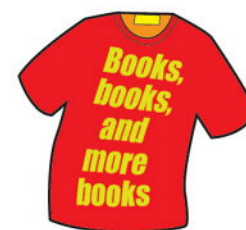

- 1 Joe doesn't eat meat. 2 Bob .....



- 3 I ..... 4 My parents .....



- 5 Tom ..... 6 Larry and Kyle .....

## Puzzle page 93, puzzle 2

### 5 Over to you!

Complete the chart with information about you and a friend. Tell the class.

	You	Your friend
love	<u>hip-hop</u>	<u>computers</u>
(don't) play	.....	.....
(don't) like	.....	.....
(don't) speak	.....	.....

I love hip-hop music. My friend loves computers. I don't play volleyball. My friend doesn't play basketball.



# Building the topic



## Vocabulary

### Clothes

1 Label the pictures with the words below. Then listen, check, and repeat.

cap jacket jeans shorts sneakers  
sweatpants sweatshirt **T-shirt**

2 Read and listen to the conversation. Then match the clothes below with the correct people.

- 1 sneakers Bruno's sister
- 2 T-shirt \_\_\_\_\_
- 3 jacket \_\_\_\_\_
- 4 sweatshirt and cap \_\_\_\_\_
- 5 shorts \_\_\_\_\_
- 6 sweatpants \_\_\_\_\_

3 Write the clothes.

Clothes I wear at school: \_\_\_\_\_,

Clothes I wear on the weekends: \_\_\_\_\_,

Bruno: Do you want to see pictures of my family?

Maki: Yes, I do.

Bruno: OK. That's my mother.

Maki: Does she play sports?

Bruno: Yes, she does. She plays tennis. That's me and my brother.

Maki: Do you like basketball?

Bruno: Yes, we do. We love the Chicago Bulls.

Maki: Who is that?

Bruno: That is my sister.

Maki: Does she listen to rock music?

Bruno: No, she doesn't. She hates rock music, but she likes hip-hop music.

Maki: Is that your father?

Bruno: Yes, it is.

Maki: Does he like movies?

Bruno: Yes, he does. He loves old movies from the 1950s.



## Grammar

### Simple present (yes / no questions)

Asking about facts and habits in the present

#### 1 Look at the chart.

Questions	Short answers
Do I <b>wear</b> jeans?	Yes, I <b>do</b> . / No, I <b>don't</b> .
Do you <b>love</b> music?	Yes, you <b>do</b> . / No, you <b>don't</b> .
Does he / she / it <b>eat</b> meat?	Yes, he / she / it <b>does</b> . / No, he / she / it <b>doesn't</b> .
Do we <b>read</b> books?	Yes, we <b>do</b> . / No, we <b>don't</b> .
Do you <b>speak</b> Japanese?	Yes, you <b>do</b> . / No, you <b>don't</b> .
Do they <b>watch</b> movies?	Yes, they <b>do</b> . / No, they <b>don't</b> .

#### 2 Put the words in order to make questions.

- you / soccer / Do / hate  
*Do you hate soccer* .....
- they / Do / T-shirts / wear  
.....
- Does / TV / watch / your brother  
.....
- you and your friends / music / listen to / Do  
.....
- Sandra / languages / four / Does / speak  
.....

#### 3 Match the short answers with the questions in exercise 2.

- Yes, we do. ....
- Yes, they do. ....
- No, she doesn't. ....
- No, I don't. **1** .....
- Yes, he does. ....

#### 4 Make questions with the words below. Then look at the backpacks and write the correct short answer.

- (Terry / like / hip-hop)  
*Does Terry like hip-hop* .....?  
*Yes, he does* .....
- (Julia / read / art books)  
.....?
- (Terry / listen to / pop music)  
.....?
- (Terry and Julia / play / sports)  
.....?
- (Julia / eat / meat)  
.....?



### Puzzle page 93, puzzle 3

#### 5 Over to you!

Ask and answer the questions in class.

- love art / hip-hop music / English?
- wear sweatpants / T-shirts / sneakers?
- have a favorite cap / color / rock band?

Student A: *Do you love art?*

Student B: *Yes, I do.*

Student A: *Does your mom wear sweatpants?*

Student B: *No, she doesn't.*

Now tell the class about another student.

*Lara loves art. Her mom doesn't wear sweatpants.*



## Living English

I like work.  
I can sit and look  
at it for hours.



I DON'T MAKE STUPID  
MISTAKES, ONLY  
SMART ONES.

Life is time.  
You fill in the blanks.



Friends listen to what you  
say. Best friends listen  
to what you don't say.

Life is short. Smile,  
dance, celebrate!

I hate the morning.  
I sleep until 12 o'clock.

DO YOU NEED  
A FRIEND? GET  
A DOG!



### Reading ◀

**1** Read the slogans on the wall. Choose the correct description below.

- a These messages are serious.
- b Some of these messages are serious.
- c These messages aren't serious.

**2** Match the slogans with the definitions.

- |  |       |
|--|-------|
| 1 I like work. I can sit and look at it for hours.                           | f     |
| 2 Life is short. Smile, dance, celebrate!                                    | ..... |
| 3 Life is time. You fill in the blanks.                                      | ..... |
| 4 Do you need a friend? Get a dog!   | ..... |
| 5 I hate the morning. I sleep until 12 o'clock.                              | ..... |
| 6 Friends listen to what you say. Best friends listen to what you don't say. | ..... |
| a Dogs are good friends.   |       |
| b Do things in your life.  |       |
| c I don't get up in the morning.   |       |
| d It isn't necessary to speak to be good friends.                            |       |
| e Enjoy life.  |       |
| f Work is interesting to look at, but not fun to do.                         |       |

**3** Now choose a slogan for you. Write it in your notebook.



## Listening

### Describing your favorite sports team

1 Listen Look at the photo and listen to Matthew. Answer the questions.



- 1 Where is Matthew from? .....
- 2 What's the name of his favorite basketball team? .....
- 3 What's the nationality of his favorite basketball player? .....

2 Listen again. Circle the correct option.

- 1 Matthew's favorite colors are red and blue / white.
- 2 He has Houston Rockets sneakers / clothes.
- 3 He has a Houston Rockets watch / cell phone.
- 4 The Houston Rockets sneakers are expensive / cheap.
- 5 Yao Ming wears number 7 / 11 on his T-shirt.
- 6 Yao Ming is 1.89 meters / 2.29 meters.

## Speaking

### Talking about habits

1 Listen Listen and read.

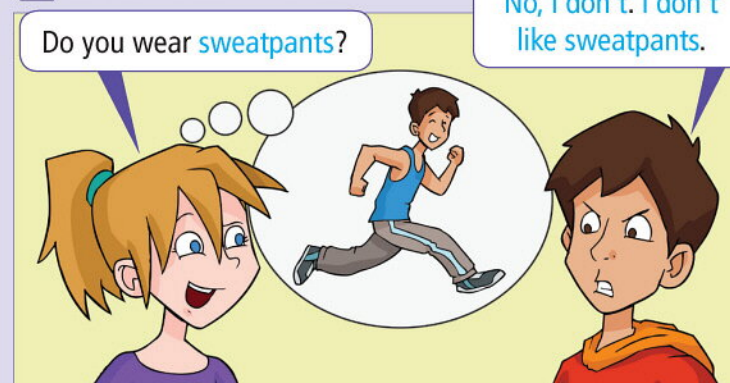

2 Listen Look at the Pronunciation box. Listen to the examples.

Pronunciation	
ea sounds	
• There are different "ea" sounds.	
/ɛ/	/i/
sweatpants	eat

Listen again and repeat.

3 Listen. Put the words in the correct column.

cheap sneakers sweatshirt wear

/ɛ/	/i/
<u>sweatshirt</u>	

4 Practice the dialogue in exercise 1.

5 Now change the words in blue. Write a new dialogue. Then practice the dialogue in class.



# ROUND-UP

## Writing

### My preferences

- 1 Look at the Writing skills box.

#### Writing skills

*because*

- We use *because* to give reasons.  
I wear a cap **because** I think it's cool.

- 2 Read the text. Circle the examples of *because*.

#### All about me

I'm Mariana and I'm 13 years old. I'm Mexican. I live with my parents and my grandparents in Mexico City. I go to Lomas High School. I like history because it's interesting, but I hate math because it's difficult.

I listen to pop and rock music, but I don't listen to mariachi because it isn't cool. I love Evanescence, the American rock band. I watch TV and DVDs a lot because I love movies. I wear jeans, T-shirts, and sneakers. I don't wear caps.



- 3 Fill in the chart with information about Mariana. Write a reason where appropriate.

Mariana	You
goes to <u>Lomas High School</u>	I go to .....
likes <u>history - interesting</u>	I like .....
hates .....	I hate .....
listens to .....	I listen to .....
doesn't listen to .....	I don't listen to .....
watches .....	I watch .....
wears .....	I wear .....
doesn't wear .....	I don't wear .....

- 4 Now fill in the chart with information about you. Write a reason where appropriate.

- 5 Write about your preferences. Use the text and the chart to help you. Use *because* to give reasons.

## I can ...

- 1 Fill in the blanks with *don't* / *doesn't*.

- My teacher doesn't speak French. He speaks English.
- My friends ..... like soccer. They like basketball.
- Julia ..... eat meat. She eats fish.
- I ..... like math. I like geography.

I can talk about facts and habits in the present.

Yes, I can.  I need more practice.

- 2 Fill in the blanks with *do* / *does* / *don't*.

- Do you read magazines? Yes, I do.
- ..... she eat meat? No, she .....
- ..... they speak Spanish? Yes, they .....
- ..... you wear pink jeans? No, I .....

I can ask about facts and habits in the present.

Yes, I can.  I need more practice.



# puzzle 1

Unscramble the verbs.  
Use the letters in the circles to make another verb.

- T H A E     hate
- I K E L     \_\_\_\_\_
- E A K P S     \_\_\_\_\_
- D A R E     \_\_\_\_\_
- E R W A     \_\_\_\_\_
- T E A     \_\_\_\_\_
- O L V E     \_\_\_\_\_
- E N D C A     \_\_\_\_\_



# puzzle 2

Do the crossword.

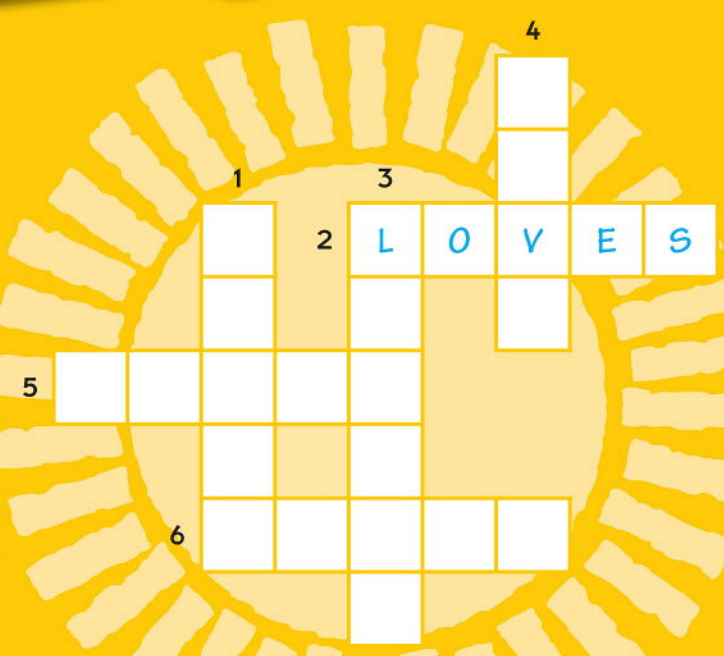

### ACROSS

- 2 My sister \_\_\_\_ *One Direction*. She's crazy about them!
- 5 My teacher \_\_\_\_ a lot of books.
- 6 I don't \_\_\_\_ Chinese.

### DOWN

- 1 Her brother \_\_\_\_ a sweatshirt and sweatpants to school.
- 3 We don't \_\_\_\_ to our MP3 players at school.
- 4 Lady Gaga doesn't \_\_\_\_ in Canada. Her house is in California.

# puzzle 3

S	W	E	T	A	S	J	A	M	P	C	A
W	H	I	T	R	W	C	O	R	T	B	-
E	J	-	S	N	E	A	K	E	R	S	A
A	E	I	W	T	A	R	L	C	-	H	M
T	A	R	E	H	T	P	A	N	S	T	J
H	N	T	A	E	S	H	O	R	T	S	A
P	S	M	T	S	H	O	R	T	R	E	C
E	C	A	P	B	I	T	R	I	H	G	K
R	B	L	A	E	R	Y	E	P	A	C	E
S	E	H	N	N	T	-	S	H	I	R	T
-	C	A	T	S	H	O	T	R	S	F	K
T	R	A	S	W	J	E	A	C	K	E	T

Circle the words in the wordsearch.

- CAP
- JACKET
- JEANS
- SHORTS
- SNEAKERS
- SWEATSHIRT
- SWEATPANTS
- T-SHIRT

# puzzle 4

Use the code and write the secret question. Then answer it.

A	B	C	D	E	F	G	H	I
22	⊗	14	1	16	⊗	⊗	12	⊗
J	K	L	M	N	O	P	Q	R
7	⊗	23	⊗	11	25	⊗	⊗	5
S	T	U	V	W	X	Y	Z	
18	21	8	⊗	9	⊗	3	⊗	

D O Y O U

1 25    3 25 8    9 16 22 5

7 16 22 11 18 21 25

18 14 12 25 25 23

Your answer: \_\_\_\_\_



## 8

## Free time

## Introducing the topic

## Vocabulary

## Going out

- 1 Look at the photos. Complete the labels with the words below. Then listen, check, and repeat.

bowling alley   concert   country   dance  
school   party   skate park   soccer game  
~~sports center~~   theme park   youth club

- 2 Listen. Write the correct names.

Kenji   Lucas   Monica   Sophie and Sam

- 1 Lucas goes to a dance school and parties.  
2 ..... goes to theme parks and concerts.  
3 ..... go to the skate park and the bowling alley.  
4 ..... goes to a youth club and to soccer games.

- 3 Complete the sentences with places you go.

- 1 I go to ..... and .....  
2 I don't go to ..... or .....

## OBJECTIVES

- going out
- simple present (*Wh-* questions)
- leisure activities
- expressions of frequency
- free time around the world
- asking about free time activities
- talking about frequency
- writing: my free time

1 go to the sports center

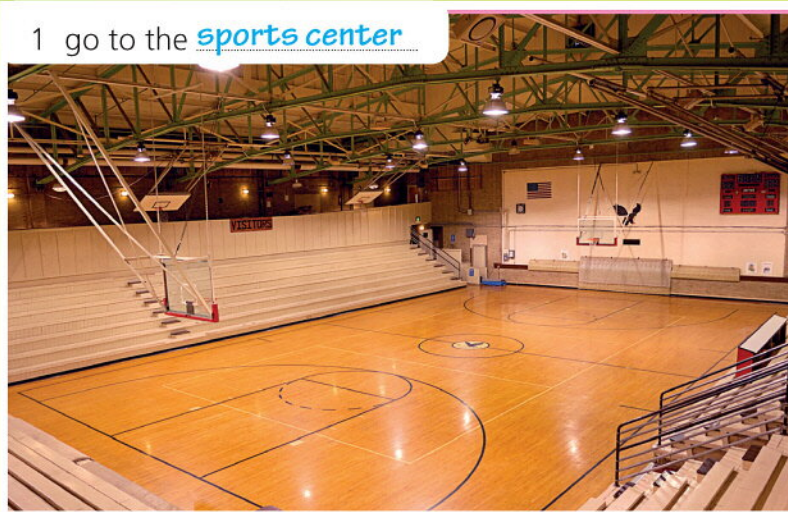

2 go to a .....



**Puzzle** page 103, puzzle 1

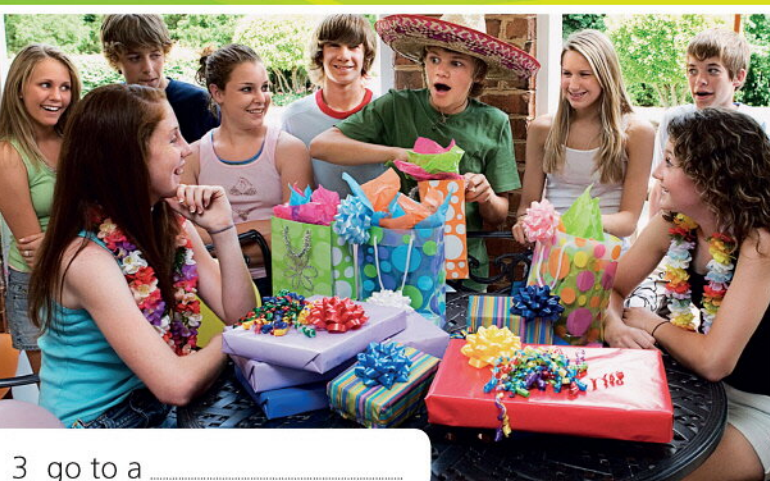

3 go to a .....



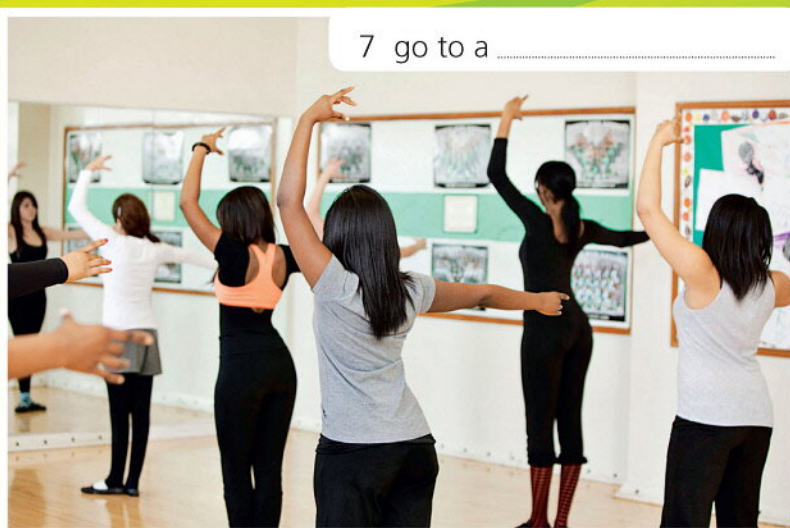
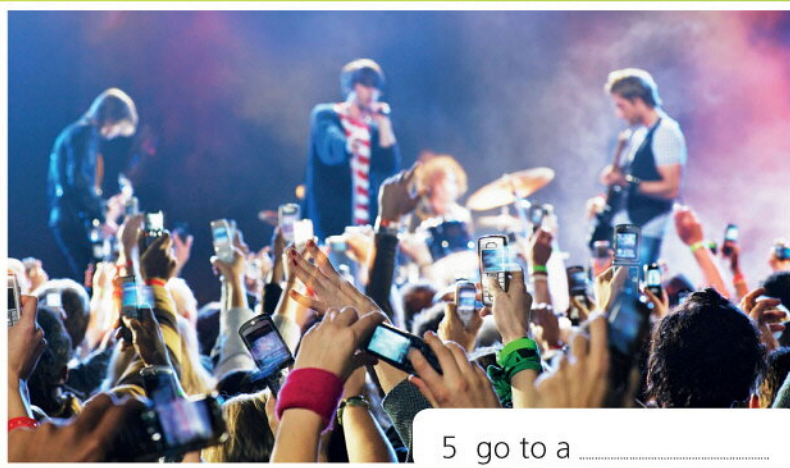
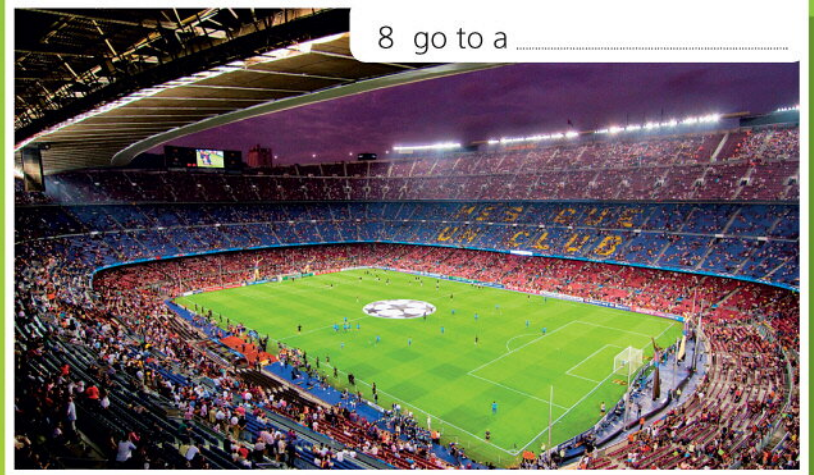



## Exploring the topic



# music UNLIMITED

**Q ▶** (A) What's your name and where are you from?

**A ▶** My name's Reina and I'm fifteen. I'm from Boston in the U.S. and I go to Walker High School. My favorite subject is music. I'm in the show choir at school. It's called Music Unlimited.

**Q ▶** (B) .....

**A ▶** On Mondays after school.

**Q ▶** (C) .....

**A ▶** In the lunchroom. We don't meet in the music room. It's small.

**Q ▶** (D) .....

**A ▶** We sing and dance, and our teacher, Bob, plays the piano. We sing and dance in concerts, too.

**Q ▶** (E) .....

**A ▶** Because I'm happy when I sing and dance. On the weekends, I go to concerts and dance school, too!

**Q ▶** (F) .....

**A ▶** I listen to the songs on my MP3 player, and then I sing them in my bedroom.

**Q ▶** (G) .....

**A ▶** A show called *Glee*. It's about a show choir in Ohio called New Directions.

## Reading

**1** Read the interview. Is a show choir ... ?

- a a sports club
- b a singing club
- c a youth club

**2** Read again and listen. Match the questions below with the answers A–G in the text. Then listen and check.

- 1 What do people do in the show choir? .....
- 2 What's your favorite TV show? .....
- 3 When does the show choir meet? .....
- 4 What's your name and where are you from? **A**
- 5 Why do you go to the show choir? .....
- 6 Where do you meet? .....
- 7 How do you learn the songs? .....

**3** Read again. Answer the questions.

- 1 Where does Reina live?  
**She lives in Boston** .....
- 2 What school does she go to?  
.....
- 3 Who is Bob?  
.....
- 4 What does he do for the show choir?  
.....
- 5 Where does Reina listen to her MP3 player?  
.....
- 6 What's the name of the show choir in *Glee*?  
.....



## Grammar

### Simple present (Wh- questions)

Asking about regular activities

#### 1 Look at the chart.

Questions			
What	do	I	sing?
Where	do	you	meet?
When	does	he / she / it	go to the beach?
Why	do	we	like the youth club?
How	do	you	play basketball?
What	do	they	do on the weekends?

#### 2 Circle the correct question word.

- When / Where do you go to the youth club?  
On Fridays at eight o'clock.
- Why / How do you play the guitar?  
Because I love music.
- Where / What do you do in the evenings?  
I watch TV in my room.
- When / How do you go to school?  
My mom drives me.
- Where / How do they have lunch?  
In the fast food restaurant.

#### 3 Put the words in order to make questions.

- you / How / in Japanese / "Hello" / say / do  
How do you say "Hello" in Japanese ?
- do / listen to / What / you / on your MP3 player  
..... ?
- Why / Sara / to soccer games / go / does  
..... ?
- does / start / When / the English class  
..... ?
- Eduardo / does / go / on Saturdays / Where  
..... ?

#### 4 Match the answers with the questions in exercise 2.

- Because she likes soccer. ....
- "Konnichiwa." 1
- He goes to dance school. ....
- At eleven o'clock. ....
- Hip-hop music. ....

#### 5 Look at Susanna's answers. Write the questions.



You: (1) What do you do on Saturdays ?

Susanna: I go to a youth club with my friends on Saturdays.

You: (2) .....  
your friends?

Susanna: I meet my friends in front of the movie theater.

You: (3) .....  
the youth club?

Susanna: We go by bike to the youth club.

You: (4) .....  
the youth club?

Susanna: We like the youth club because it's fun.

You: (5) .....  
there?

Susanna: We relax and listen to music.

You: (6) ..... ?

Susanna: I go to bed at eleven thirty.

## Puzzle page 103, puzzle 2



#### 6 Over to you!

Write five questions with *What*, *Where*, *When*, *Why*, and *How*. Ask and answer in class.

Student A: What do you do after school?

Student B: I meet my friends and we go to the skate park.

Student A: Where do you have lunch?

Student B: I have lunch at school.



# Building the topic

## What do you do in the evenings?

How often do you ...	0	1	2	3	4	5	7
go shopping?	✓						
go to the library?			✓				
go swimming?				✓			
read books?							✓
exercise?			✓				
go out with friends?		✓					
watch TV?					✓		
go online?						✓	
play computer games?			✓				
talk on the phone?							✓

0 = never      3 = three times a week      5 = five times a week  
 1 = once a week      4 = four times a week      7 = every day  
 2 = twice a week



### Vocabulary

#### Leisure activities

1 Match the photos with the words below. Then listen, check, and repeat.

exercise	<input checked="" type="checkbox"/> 3	go to the library	<input type="checkbox"/>
go online	<input type="checkbox"/>	play computer games	<input type="checkbox"/>
go out with friends	<input type="checkbox"/>	read books	<input type="checkbox"/>
go shopping	<input type="checkbox"/>	talk on the phone	<input type="checkbox"/>
go swimming	<input type="checkbox"/>	watch TV	<input type="checkbox"/>

2 Look at the chart and fill in the blanks with the correct verbs.

- I never *go shopping* ..... in the evenings.
- I ..... once a week.
- I ..... three times a week.
- I ..... five times a week.
- I ..... and ..... every day.



## Grammar

### Expressions of frequency

Talking about how often we do activities

#### 1 Look at the chart.

##### Questions and answers

**How often** do you go swimming?

I **never** go swimming.

We go swimming **twice a week**.

**How often** does he / she / it read books?

He reads books **once a month**.

She reads books **three times a year**.

#### 2 Replace the words in blue with the expressions of frequency below.

every day    four times a week    once a month  
three times a year    twice a day    ~~twice a week~~

1 They go swimming **on Mondays and Fridays**.  
**They go swimming twice a week**

2 She goes online **every morning and every evening**.





3 We go to concerts **in April, May, and July**.

4 I exercise **on Monday, Tuesday, Wednesday, Thursday, Friday, Saturday, and Sunday**.

5 My mom goes to the library **once in January, once in February, once in March...**

6 Leon goes out with friends **on Tuesdays, Thursdays, Fridays, and Saturdays**.

#### 3 Look at Victoria's schedule. Complete the questions and answers.

<b>Monday</b> 4 p.m. tennis lesson	
<b>Tuesday</b> 7 p.m. guitar lesson	
<b>Wednesday</b> 5 p.m. go to the library	
<b>Thursday</b> 7 p.m. guitar lesson	
<b>Friday</b> 4 p.m. tennis lesson	
<b>Saturday</b> 11 a.m. guitar lesson	
<b>Sunday</b> 2 p.m. go swimming	

1 **How often do you** have tennis lessons?

**I have tennis lessons twice a week**

2 ..... have guitar lessons?

3 ..... go to the library?

4 ..... go swimming?

5 ..... relax?

I ..... relax!

## Puzzle

page 103, puzzle 3



#### 4 Over to you!

Ask and answer in class about free time activities.

Student A: **How often do you go to a soccer game?**

Student B: **Once a month. How often do you talk on the phone?**

Student A: **Every day!**



## Free time around the world

**Madison, 15**, THE UNITED STATES

GLEE CLUB SINGER

What is a glee club?

It's a group that meets after school.  
We play instruments and sing, and then we have shows or concerts.

Why do you do the glee club in your free time?

Because my friends are there and we all love music a lot.

How often do you practice?

We practice three times a week.  
And we have shows or competitions once a month.

**Sean, 14**, AUSTRALIA

FENCER

What is fencing?

It's an old sport. You use swords, and you fight other fencers.

Why do you like fencing?

Because it's great exercise. It's really hard.

Where do you do fencing?

There's a fencing school across from my apartment.

How often do you practice?

I practice twice a week.

Do you go to fencing competitions?

No. I'm a beginner. Maybe next year.

**Camille, 13**, FRANCE

SNOWBOARDER

Why do you snowboard?

There's snow in the mountains in France for five or six months, so snowboarding is a good activity.

Where do you snowboard?

I live near Avoriaz, a great ski resort, so I go there a lot.

Why do you like it?

Because it's good exercise, and it's really exciting and fun!

How often do you snowboard?

Only on the weekends, but I snowboard every weekend in the winter.

## Reading 🗣️

1 Look at the Reading skills box.

## Reading skills

## Using dictionaries

- You can use a dictionary to find words that you don't know.

2 Put the words below in alphabetical order.

fencer  snow  practice   
competition  resort

Now find the words in your dictionary. Write the meaning in your language.

3 Read the interviews. Are they about...?

- a cheerleading  
b hobbies  
c sports

4 Read again. Answer the questions.

1 What does Madison do in her free time?  
glee club

2 How often does she practice?  
.....

3 What is Sean's hobby?  
.....

4 Where does he do it?  
.....

5 How often does he do it?  
.....

6 Does Sean go to competitions?  
.....

7 What is Camille's hobby?  
.....

8 How often does she do it?  
.....



## Listening

### Asking about free time activities

- 1 Listen to the conversation. Check (✓) the chart with Mark's answers.

How often do you ...	Never	Twice a week	Once a month
go out with friends?		✓	
exercise?			
go to the movie theater?			
go to concerts?			



- 2 Listen again. Circle T (True) or F (False).

- The interviewer's name is Mary. T / **F**
- Mark goes to the shopping mall with his friends. T / F
- He plays basketball for exercise. T / F
- He hates action movies. T / F
- He doesn't like rock music. T / F
- He thinks concerts are expensive. T / F

## Speaking

### Talking about frequency

- 1 Listen and read.



- 2 Look at the Pronunciation box. Listen to the examples.

### Pronunciation

#### Silent letters

- Some words have "silent" letters. We don't pronounce them.

of~~en~~ wh~~ere~~ Wed~~ne~~sday

Listen again and repeat.

- 3 Listen. Cross out the silent letters.

- w~~h~~ere
- walk
- listen
- know

- 4 Practice the dialogue in exercise 1.

- 5 Now change the words in blue. Write a new dialogue. Then practice the dialogue in class.

**Puzzle** page 103, puzzle 4





# ROUND-UP

## Writing

### My free time

1 Look at the Writing skills box.

**Writing skills**

**too**

- We use **too** at the end of a sentence to add another point.

I go to a dance club once a week. I play soccer once a week, **too**.

2 Read the text. Circle the examples of **too**. What do we use before **too**?

**MY FREE TIME**

I talk to my friends on the phone every day. We talk about clothes and music.

I listen to music every day, too. I love rap music, but I never listen to rock music. I don't like it!

I go to a youth club once a week. It's fun. We play computer games there. We listen to music, too.

I exercise two or three times a week. I go swimming at the sports center, and I play tennis, too.

I go out with friends every weekend. We go to the shopping mall or we go to the bowling alley.

I go to a soccer game once a month. I don't go every week because it's expensive!



3 Fill in the chart with Daniela's free time activities.

	Daniela	You
every day	talk on the phone	
	listen to music	
once a week	.....	
	.....	
	.....	
two or three times a week	.....	
	.....	
	.....	
every weekend	.....	
	.....	
	.....	
once a month	.....	

4 Now fill in the chart with your free time activities.

5 Write a text about your free time. Use the text and the chart to help you.

## I can ...

1 Write questions for the answers.

- Where do you go on Saturday nights?  
I go to the movie theater.
- ..... go to school?  
I go to school by bus.
- ..... like soccer?  
We like soccer because it's fun.
- ..... go to bed?  
He goes to bed at ten thirty.

I can ask ask about regular activities.

Yes, I can.  I need more practice.

2 Write four sentences about your activities. Use **often**, **never**, **once a week**, and **three times a year**.

- I go swimming once a week .....
- .....
- .....
- .....

I can talk about how often I do activities.

Yes, I can.  I need more practice.



**puzzle** 1

**Do the puzzle.  
What's the mystery word?**

- 1 Where do you dance? At the \_\_\_\_\_.
- 2 Where do you do sports? At the \_\_\_\_\_.
- 3 Where do you live? In the city? No, in the \_\_\_\_\_.
- 4 When do you watch a \_\_\_\_\_? Every Saturday.
- 5 What do you do at the \_\_\_\_\_? I skateboard.
- 6 What do you do on your birthday? I have a \_\_\_\_\_.
- 7 Who do you meet at the \_\_\_\_\_? My friends.

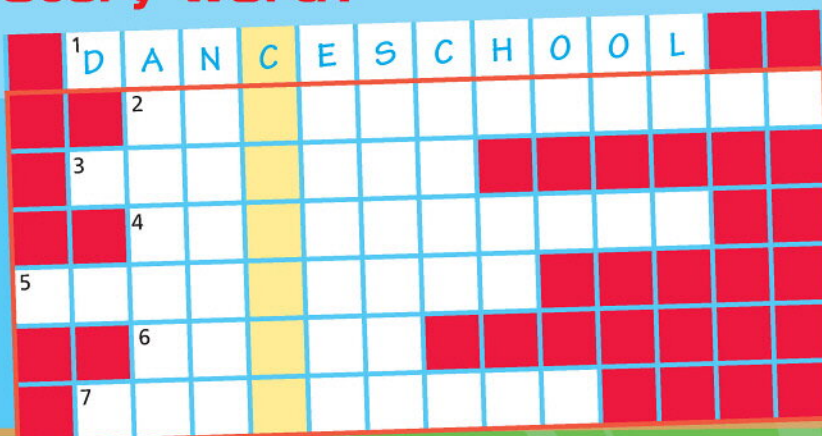

**puzzle** 2



Unscramble the places. Use the letters in the circles to answer the question.

- 1 R P T A Y ..... party
- 2 C S C E O R M E A G .....
- 3 T S O P R S T E C N R E .....
- 4 O L N B I W G L E A Y L .....
- 5 O H Y U T L C B U .....

Where does Maya go on the weekend?

**puzzle** 3

Match the people and the pictures. Then complete the sentences.

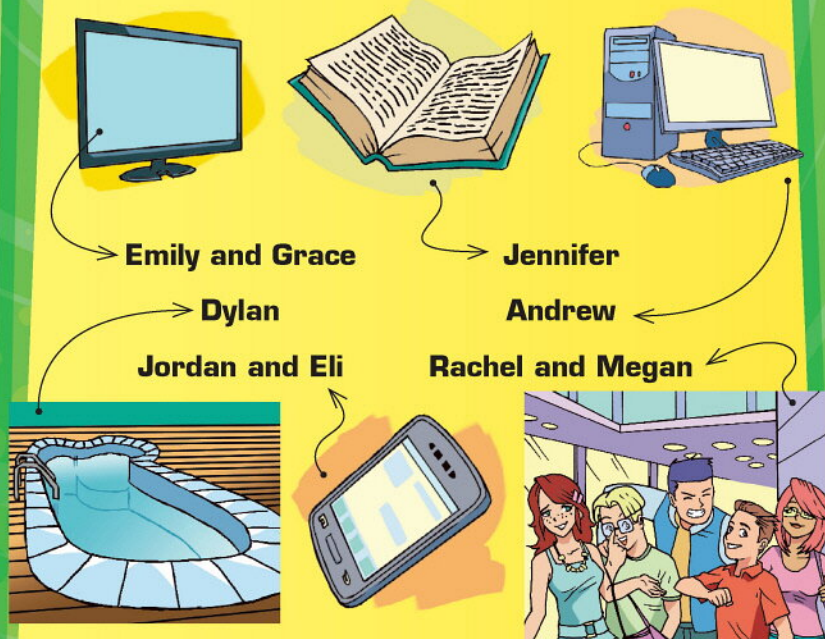

- 1 Emily and Grace watch TV once a week.
- 2 Dylan ..... twice a week.
- 3 Jordan and Eli never .....
- 4 Jennifer ..... three times a week.
- 5 Andrew ..... every day.
- 6 Rachel and Megan ..... on Saturdays.

**puzzle** 4

A	B	C	D	E	F	G	H	I
J	K	L	M	N	O	P	Q	R
S	T	U	V	W	X	Y	Z	

- Look at the Braille code.
- Write the words.

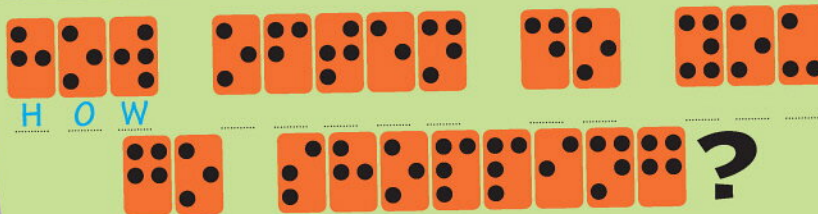

What's your answer to the question? .....



# D Review

## Vocabulary

### Preferences









1 Complete the sentences with the verbs below.

eat hate like listen live **love** read  
speak wear

- 1 I **love** Yao Ming. He's fantastic.
- 2 I Spanish.
- 3 I one book a month.
- 4 I to my MP3 player every day.
- 5 I black clothes because they're cool.
- 6 I horror movies. They're terrible.
- 7 My favorite music is hip-hop. I Jay-Z.
- 8 I'm a vegetarian. I don't meat.
- 9 I in Bogotá in Colombia.



### Clothes



2 Label the clothes.

	1 <b>shorts</b>		5
	2		6
	3		7
	4		8

### Going out

3 Look at the pictures. Write the place.

	1 <b>dance school</b>
	2
	3

	4
	5
	6

### Leisure activities

4 Match 1-8 with a-h.

- |          |                  |
|----------|------------------|
| 1 go     | a TV             |
| 2 read   | b with friends   |
| 3 go     | c shopping       |
| 4 talk   | d books          |
| 5 go out | e the library    |
| 6 play   | f on the phone   |
| 7 go to  | g online         |
| 8 watch  | h computer games |

### Grammar

#### Simple present (negative)

1 Correct the sentences. Then write affirmative sentences. Use the words in parentheses.

- 1 Jill wears jeans. **X** (shorts)  
Jill doesn't wear jeans  
She wears shorts
- 2 Kyle and Deb listen to hip-hop music. **X** (jazz)  
 \_\_\_\_\_  
 \_\_\_\_\_
- 3 You go shopping every day. **X** (swimming)  
 \_\_\_\_\_  
 \_\_\_\_\_
- 4 Damon likes basketball. **X** (soccer)  
 \_\_\_\_\_  
 \_\_\_\_\_
- 5 We go online. **X** (play computer games)  
 \_\_\_\_\_  
 \_\_\_\_\_



## Simple present (yes / no questions)

**2** Fill in the blanks with *Do* or *Does*. Then match the questions with the answers.

- 1 Do ..... you go to a dance school?
- 2 ..... your friends go to the country?
- 3 ..... your brother go to soccer games?
- 4 ..... you go to the skate park?
- 5 ..... your mom go swimming?
- 6 ..... your parents go online?

- A No, she doesn't. ....
- B Yes, they do. They love the country. ....
- C No, I don't. I don't dance. 1 .....
- D No, they don't. ....
- E Yes, I do. ....
- F Yes, he does. ....

## Simple present (Wh- questions)

**3** Write the questions. Use the words in parentheses.



Carly: Who's that?

Alexa: It's my sister, Sandra.

Carly: What does Sandra do ..... in her free time? (what / Sandra / do)

Alexa: She plays tennis. She's excellent.

Carly: (2) ..... ?  
(how often / she / play)

Alexa: Every day. My dad watches her games.

Carly: (3) ..... ?  
(why / he / watch)

Alexa: Because he is her coach.

Carly: (4) .....  
with her? (when / you / play)

Alexa: I never play with her! I can't play tennis!

Carly: (5) .....  
in your free time? (where / you / go)

Alexa: I go to the bowling alley or the movie theater.

## Expressions of frequency

**4** Look at Kim's schedule. Write sentences. Use the words in parentheses.

<b>Monday</b>	<i>sports center TV</i>
<b>Tuesday</b>	<i>TV</i>
<b>Wednesday</b>	<i>library sports center TV</i>
<b>Thursday</b>	<i>TV</i>
<b>Friday</b>	<i>youth club TV</i>
<b>Saturday</b>	<i>youth club TV</i>
<b>Sunday</b>	<i>sports center TV</i>

- 1 Kim goes to the library once a week .....  
(go to the library)
- 2 She .....  
..... (go to the sports center)
- 3 .....  
(watch TV)
- 4 .....  
..... (meet friends at the youth club)

## Study skills

### Using your coursebook

Engage has different kinds of material to help you study.

**1** Look at this list. Where can you find these things?

- 1 "I want to study new vocabulary from unit 7." a .....
  - 2 "I want grammar explanations from unit 8." .....
  - 3 "I want extra reading for unit 7." .....
  - 4 "I want a Magazine for units 7 and 8." .....
- a Workbook (page W43)  
b Engage Magazine (pages 106 and 107)  
c Workbook (page W48)  
d Workbook (page W49)



# engage

# Magazine D



1

Where are these people from? Look at the pictures. Use the words in the box to write the countries.

the US Kenya  
Saudi Arabia India



1 Saudi Arabia

2

3

4

2

Read and answer the questions.

**b** Geishas wear white makeup on their faces. They wear red lipstick and have black makeup around their eyes.



**a** This woman is from Japan. She is a geisha. She serves food and drinks in a special restaurant. She can sing, dance, and talk very well. Her long robe is a *kimono*. It's very expensive and very beautiful.



**d** These are *zori*. They're sandals. Geishas also wear *tabi*, a special kind of sock.



**c** This is an *obi*. Geishas wear them as a kind of belt. They're usually colorful and sometimes expensive, too.



**e** Where do geishas carry their cell phones? In their purses, of course.

What's your opinion?

- 1 Is a *kimono* comfortable?
- 2 Are these clothes modern or traditional? Are they beautiful?



### 3

Why do people wear different clothes? Match the reasons to the pictures. You can include more than one reason for each picture.



3



4



5



6

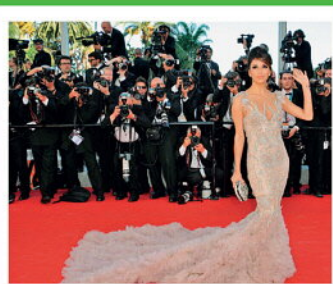

2

**a** I'm a teenager.

**b** This is my job.

**c** This is my religion.

**d** It's hot.



7



1

f/g

**e** I'm beautiful.

**f** I'm traditional.

**g** It's cold.

**h** I'm important.



8

### 4

**Over to you!**

Work in pairs. Talk about the people in Exercise 3.

- A** She wears this dress because she's beautiful.
- B** She's important, too.
- A** No, she's not very important. It's her job.

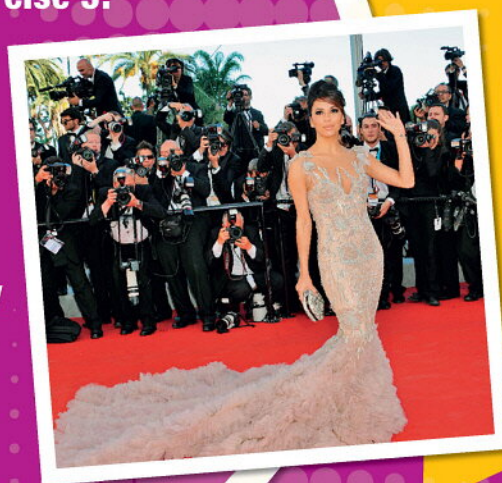

### 5

#### Project

- Choose a country.
- Research the kinds of clothes people wear in that country. Why and when do they wear those clothes?
- Find a picture and make a poster.
- Tell your class about the clothes and the country.

This woman is Russian. This coat and hat are important in Russia because it's cold there!





# Welcome

## Alphabet

1 Complete the chart with the letters.

a c e i k m o r u v w x

/eɪ/	/i/	/ɛ/	/aɪ/	/oʊ/	/u/	/ɑː/
(1) <u>a</u>	<b>b</b>	<b>f</b>	(8) _____	(9) _____	<b>q</b>	(12) _____
<b>h</b>	(3) _____	<b>l</b>	<b>y</b>	(10) _____	(11) _____	
<b>j</b>	<b>d</b>	(6) _____				
(2) _____	(4) _____	<b>n</b>				
	<b>g</b>	<b>s</b>	(7) _____			
	<b>p</b>					
	<b>t</b>					
	(5) _____					

## Numbers 0–20

2 Write the answers.

- seven + six = thirteen
- nineteen – eight = \_\_\_\_\_
- four + twelve = \_\_\_\_\_
- twenty ÷ two = \_\_\_\_\_
- five x three = \_\_\_\_\_
- eighteen – one = \_\_\_\_\_

## Colors

3 Circle ten colors in the wordsearch. Then write the words.

N	R	E	D	U	W	L	A	P
W	A	S	B	R	O	W	N	U
H	P	G	L	I	L	Y	E	R
I	O	R	A	N	G	E	L	P
T	F	E	C	H	E	L	X	L
E	N	E	K	A	B	L	U	E
P	I	N	K	R	O	O	B	Y
A	C	B	Y	O	I	W	E	S

- 1 red
- 2 b\_\_\_k
- 3 w\_\_\_\_\_
- 4 g\_\_\_\_\_
- 5 p\_\_k
- 6 y\_\_\_\_\_
- 7 p\_\_\_\_\_e
- 8 o\_\_\_\_\_
- 9 b\_\_e
- 10 br\_\_\_\_\_





## Classroom objects

1 Complete the crossword.

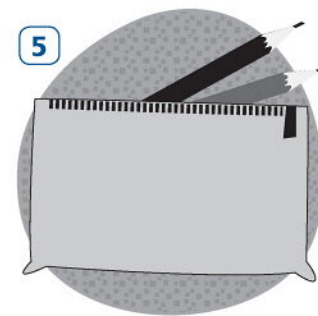
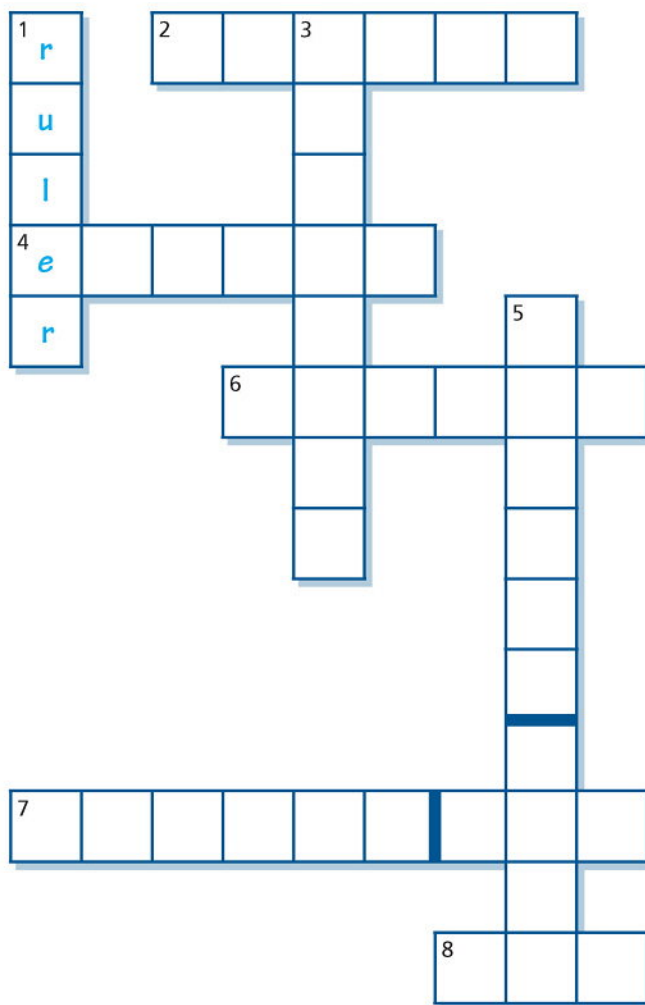
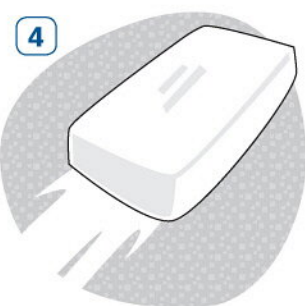
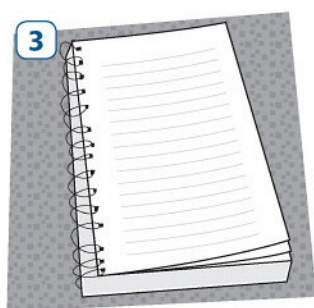
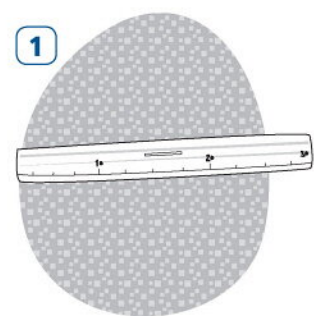

## Days of the week

2 Unscramble the days of the week. Write them in the correct order.

ySdanu Fdaiyr auSydrta uhTdsrya desdnyaeW oynMad yTdseau

- 1 Monday .....
- 2 .....
- 3 .....
- 4 .....
- 5 .....
- 6 .....
- 7 .....





## Months of the year

1 Write the months in the correct order.

April December  
 August February  
 JANUARY June  
 March November  
 May JULY October  
 September

- 1 January
- 2 \_\_\_\_\_
- 3 \_\_\_\_\_
- 4 \_\_\_\_\_
- 5 \_\_\_\_\_
- 6 \_\_\_\_\_
- 7 \_\_\_\_\_
- 8 \_\_\_\_\_
- 9 \_\_\_\_\_
- 10 \_\_\_\_\_
- 11 \_\_\_\_\_
- 12 \_\_\_\_\_

## Animals

2 Find eight animals in the word snake. Then write the words.

lhorseahhamsterrsnakedpcatstbirdgdogfmousenfishh

- 1 \_\_\_\_\_
- 2 \_\_\_\_\_
- 3 \_\_\_\_\_
- 4 \_\_\_\_\_
- 5 \_\_\_\_\_
- 6 \_\_\_\_\_
- 7 \_\_\_\_\_
- 8 \_\_\_\_\_

## Numbers 21–100

3 Complete the puzzle.

22	1 t w e n t y - t w o																			
81	2																			
50	3																			
46	4																			
74	5																			
98	6																			
82	7																			
27	8																			
39	9																			
65	10																			



What's this number? Write it here: \_\_\_\_\_







## Telling the time

1 Match the times with the clocks.

- 1 It's six o'clock. b
- 2 It's three thirty. ....
- 3 It's five past eight. ....
- 4 It's two fifteen. ....
- 5 It's twelve twenty. ....
- 6 It's five forty-five. ....
- 7 It's seven oh five. ....
- 8 It's one forty. ....

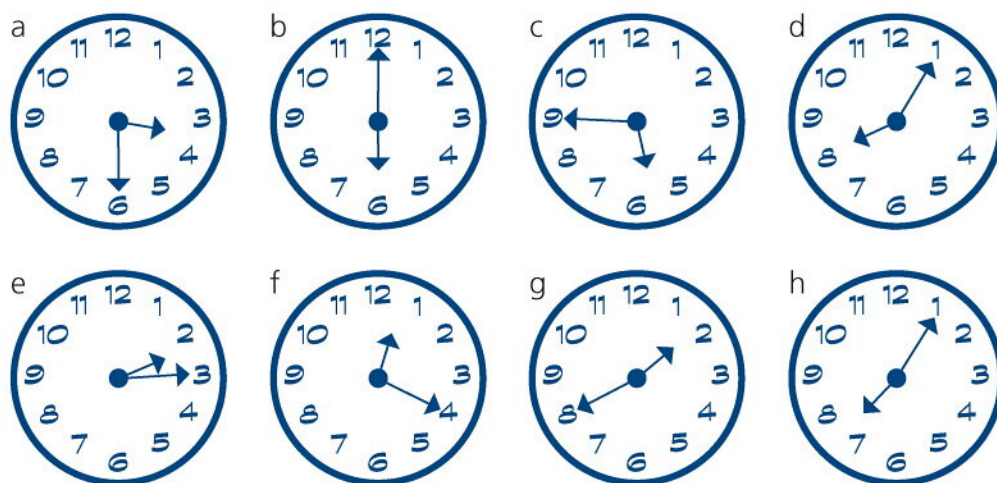

## Classroom language

2 Find six classroom instructions in the word snake. Then label the pictures with the words.

e a l i s t e n n s l o o k c w m a t c h o a p r e a d d l v r e p e a t p z w r i t e



1 listen .....



2 .....



3 .....



4 .....

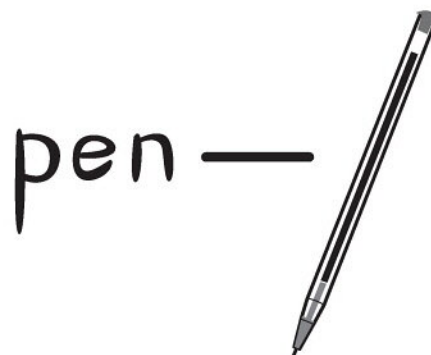

5 .....

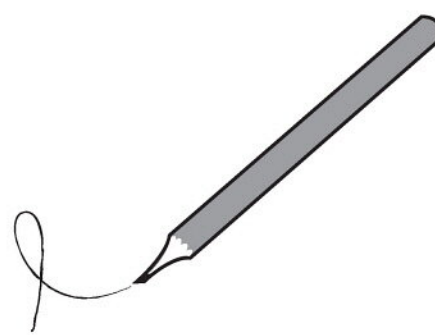

6 .....



## Classroom language

1 Fill in the blanks with the words below.

Can    **How**    mean    What    you

- 1 **How** ..... do you spell "London"?
- 2 What does "notebook" .....
- 3 ..... you repeat that, please?
- 4 How do ..... say "bonita" in English?
- 5 ..... page is it?

## Subject pronouns

2 Fill in the blanks with the words below.

He    +    She    They    We    You

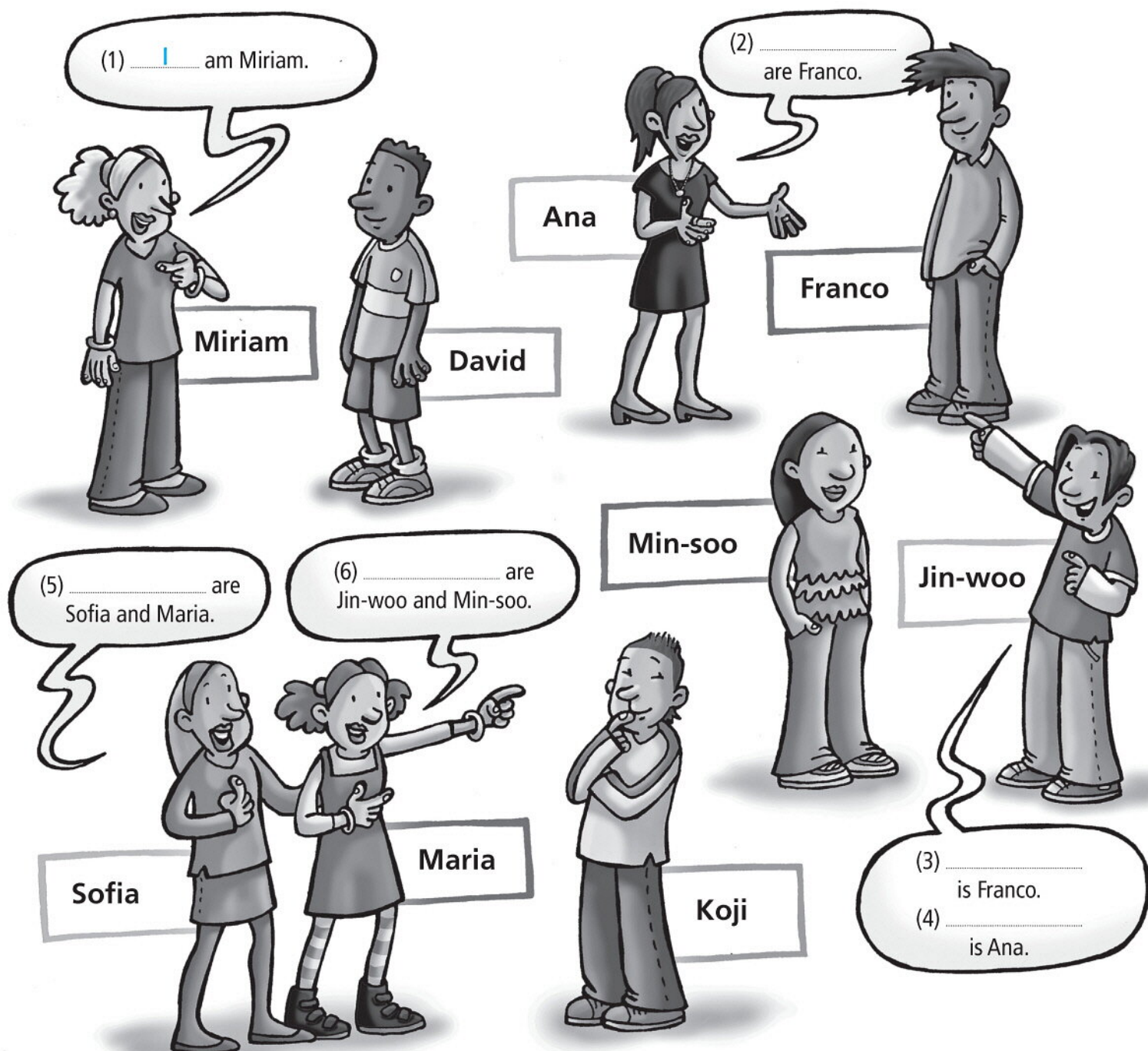



# 1 Identity

## Grammar reference

### *be* (questions)

Questions	Answers
<b>What's</b> your name?	I'm Vera. / My name's Vera.
<b>Where are</b> you from?	I'm from Brazil. / I'm Brazilian.
<b>How old are</b> you?	I'm fourteen.

We use *be* to ask questions about about name, age, and nationality.

Where is Carla from?

How old is she?

### *be* (affirmative)

Affirmative	
Long form	Short form
<b>I am</b> happy.	<b>I'm</b> happy.
<b>You are</b> thirsty.	<b>You're</b> thirsty.
<b>He is</b> cold.	<b>He's</b> cold.
<b>She is</b> scared.	<b>She's</b> scared.
<b>It is</b> sad.	<b>It's</b> sad.
<b>We are</b> bored.	<b>We're</b> bored.
<b>You are</b> hot.	<b>You're</b> hot.
<b>They are</b> angry.	<b>They're</b> angry.

We use *be* for name, age, and nationality.

We also use *be* for feelings.

I'm Daichi, I'm twelve, and I'm from Japan. I'm happy.

## Word list

### Countries

Australia  
Brazil  
Guatemala  
Japan  
Mexico  
Russia  
South Africa  
Spain  
the United Kingdom  
the United States

### Nationalities

American  
Australian  
Brazilian  
British  
Guatemalan  
Japanese  
Mexican  
Russian  
South African  
Spanish

### Feelings

angry  
bored  
cold  
happy  
hot  
hungry  
sad  
scared  
thirsty  
tired



1

### Vocabulary

1 Look at the maps. Fill in the blanks with the words below.

Guatemala Japan Russia Spain South Africa the United States



1 Hi! I'm from Russia.



2 Hello! I'm from .....



3 We're from .....



4 He's from .....



5 She's from .....



6 They're from .....

2 Fill in the blanks with the nationality.

- I'm from Virginia in the United States. I'm American.
- We're from Madrid in Spain. We're .....
- He's from Vladivostok in Russia. He's .....
- I'm from Recife in Brazil. I'm .....
- She's from Los Mochis in Mexico. She's .....
- We're from San José in Guatemala. We're .....
- My friends are from Durban in South Africa. They're .....
- We're from Osaka in Japan. We're .....
- I'm from Canberra in Australia. I'm .....
- I'm from Glasgow in the United Kingdom. I'm .....

Extend your vocabulary

3 Circle the words in the wordsearch. Then fill in the blanks with the correct country.

K	A	R	V	O	F	L	A
G	F	I	N	S	R	A	E
V	I	E	T	N	A	M	G
F	O	P	G	E	N	B	Y
U	D	R	E	M	C	E	P
R	C	A	R	R	E	P	T
I	A	L	I	X	U	T	O
P	O	C	A	N	A	D	A

Canada Egypt France Peru Vietnam

- Peru is in South America.
- ..... is in Europe.
- ..... is in Asia.
- ..... is in North America.
- ..... is in Africa.



## Grammar

### 1 Circle the correct option.

- Javier: (1) What's / How's your name?  
 Stephanie: (2) My name / name's Stephanie.  
 Javier: (3) What / Where are you from?  
 Stephanie: (4) I / I'm from the United Kingdom.  
 Javier: (5) How / What old are you?  
 Stephanie: (6) I'm / It's fourteen.

### 2 Fill in the blanks with the words below.

are from How I'm name's Where

- Sara: Hi! What's your name?  
 Carla: My (1) name's Carla.  
 Sara: (2) ..... are you from?  
 Carla: I'm (3) ..... Mexico.  
 Sara: (4) ..... old (5) .....  
 you?  
 Carla: (6) ..... sixteen.

### 3 You are Mika. Fill in the blanks.

- Mika: Hello! What's (1) .....  
 .....?  
 Alicia: My name's Alicia.  
 Mika: Where (2) .....  
 .....?  
 Alicia: I'm from São Paulo in Brazil. I'm Brazilian.  
 Mika: How (3) .....  
 .....?  
 Alicia: I'm sixteen.

### 4 Fill in the blanks.

- Alicia: Hi! (1) .....  
 .....?  
 Mika: (2) ..... Mika.  
 Alicia: (3) .....  
 ..... from?  
 Mika: (4) .....  
 ..... in Japan. I'm  
 (5) .....  
 Alicia: (6) ..... old are you?  
 Mika: (7) .....

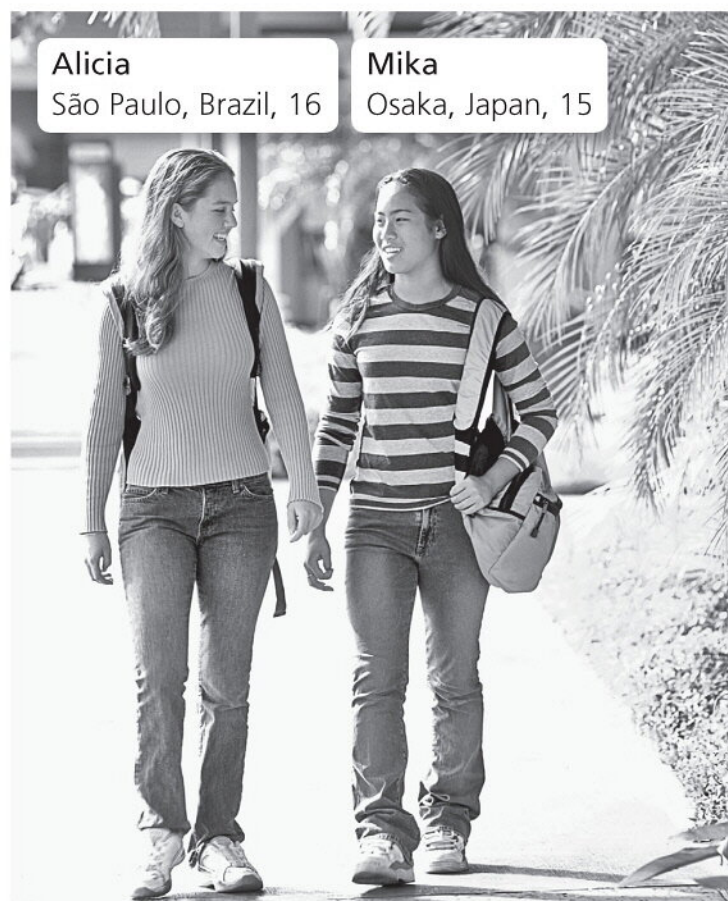



1

Vocabulary

1 Match the words with the people.

- 1 scared c
- 2 angry \_\_\_\_\_
- 3 thirsty \_\_\_\_\_
- 4 happy \_\_\_\_\_
- 5 bored \_\_\_\_\_



2 Unscramble the feelings.

- 1 oht hot
- 2 docl \_\_\_\_\_
- 3 dsa \_\_\_\_\_
- 4 diret \_\_\_\_\_
- 5 gruhny \_\_\_\_\_

3 Fill in the blanks with the words below.

busy excited sick sleepy wet

1 I'm sick \_\_\_\_\_.

2 I'm \_\_\_\_\_.

3 We're \_\_\_\_\_.

4 We're \_\_\_\_\_.

5 I'm \_\_\_\_\_.

Extend your vocabulary



## Grammar

### 1 Fill in the blanks with *am, is, or are*.

- |                        |                     |
|------------------------|---------------------|
| 1 I <b>am</b> excited. | 5 We _____ hot.     |
| 2 You _____ angry.     | 6 He _____ sick.    |
| 3 They _____ sad.      | 7 You _____ busy.   |
| 4 It _____ wet.        | 8 She _____ sleepy. |

### 2 Fill in the blanks with the words below.

He's It's I'm She's **They're** We're You're You're

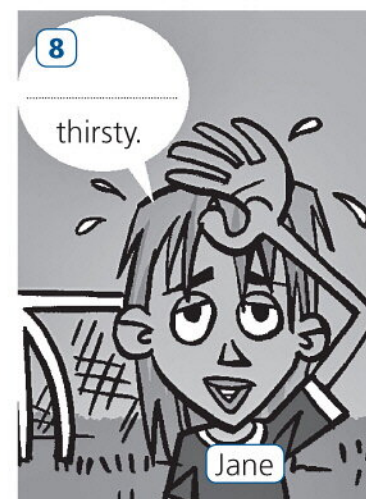
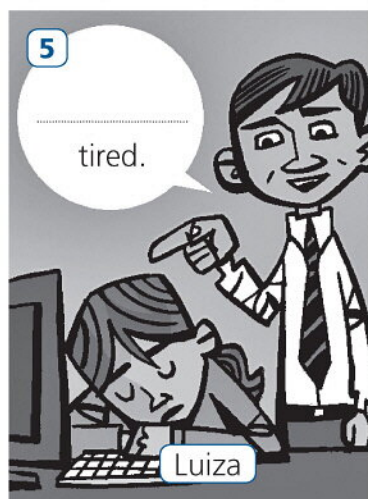
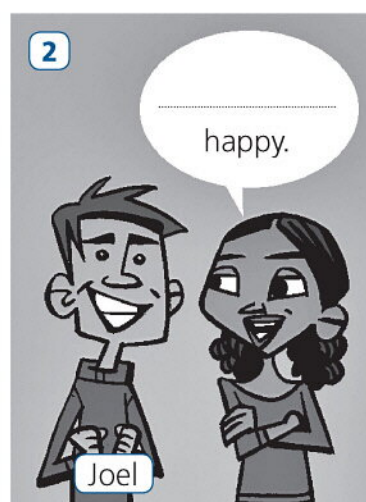

### 3 Look at the pictures in exercise 2. Complete the sentences.

- |                                 |                   |
|---------------------------------|-------------------|
| 1 Rex and Rita <b>are wet</b> . | 5 Luiza _____.    |
| 2 Joel _____.                   | 6 The fish _____. |
| 3 Hao Yu and Kwan Lin _____.    | 7 Lola _____.     |
| 4 Rob _____.                    | 8 Jane _____.     |



1

Reading

1 Scan the profiles. Answer the questions.

- 1 How old is James? fifteen
- 2 How old is Florencia? .....
- 3 How old is Alexis? .....
- 4 How old is Simon? .....
- 5 How old is Juan-Carlos? .....



Florencia is sixteen years old. Her nickname is Floppy. She's from Barcelona. She's Spanish. Right now, she's busy.



James is fifteen years old. His nickname is Jim. He's Australian. He's from Melbourne. Right now, he's happy.



Alexis and Simon are British. They're from Edinburgh. Alexis is twelve years old. Her nickname is Alex. Simon is fourteen years old. His nickname is Si. Right now, they're in France. They're cold!



Hi. I'm Juan Carlos. My nickname is Juanito. I'm from Hermosillo in Mexico. I'm thirteen years old. Right now, I'm hungry!

2 Read the profiles. Circle the correct option.

- 1 James is from Mexico / Melbourne.
- 2 Florencia's nickname is Barcelona / Floppy.
- 3 Alexis and Simon are British / United Kingdom.
- 4 Juan Carlos is Australian / hungry.

3 Write the correct name.

- 1 Her nickname is Alex. Alexis
- 2 He's from Hermosillo. ....
- 3 His nickname is Si. ....
- 4 He's happy. ....
- 5 She's busy. ....

4 Correct the information in blue. Use subject pronouns.

- 1 James is American.  
He's Australian
- 2 Florencia is sad.  
.....
- 3 Alexis is South African.  
.....
- 4 Simon is from London.  
.....
- 5 Alexis and Simon are hot.  
.....
- 6 Juan Carlos is fourteen.  
.....
- 7 Juan Carlos is Guatemalan.  
.....



# 2 My stuff

## Grammar reference

### Possessive adjectives





Subject pronoun	Possessive adjective
I am Zoe.	<b>My</b> skateboard is short.
<b>You</b> are Sara.	<b>Your</b> computer is new.
<b>He</b> is Kevin.	<b>His</b> MP3 player is blue.
<b>She</b> is Dana.	<b>Her</b> cell phone is cheap.
<b>It</b> is a computer.	<b>Its</b> price is \$40.
<b>We</b> are friends.	<b>Our</b> MP3 players are small.
<b>You</b> are sisters.	<b>Your</b> computer is fantastic.
<b>They</b> are friends.	<b>Their</b> phones are old.

We use possessive adjectives to talk about possessions.  
We do not use *the* with possessive adjectives.  
It's my bag. (NOT It's the my bag.)

### Possessive 's

We use 's to talk about possessions with names.  
He is Brian's brother.

### this / that / these / those

Singular	
<b>This</b> is a TV.	
<b>That</b> is a TV.	
Plural	
<b>These</b> are TVs.	
<b>Those</b> are TVs.	

We use *this* and *these* for things that are near to us.  
This is my cell phone. These are my books.  
We use *that* and *those* for things that are not near to us.  
That is her computer. Those are her pens.

## Word list

### Describing objects

big  
cheap  
expensive  
long  
new  
old  
short  
small

### Things in your bedroom

bed  
bedside table  
bookcase  
chair  
closet  
desk  
game console  
lamp  
magazine  
sneakers  
TV  
watch



2

### Vocabulary

**1** Unscramble the adjectives.

- 1 gbi big      3 wen .....      5 pexnesiev .....      7 peach .....
- 2 thors .....      4 lalms .....      6 goIn .....      8 dlo .....

**2** Label the pictures with the correct adjective from exercise 1.



1 short .....



2 .....



3 .....



4 .....



5 .....



6 .....



7 .....



8 .....

**3** Fill in the blanks with the words below.

clean    dirty    heavy    light    thick    thin



1 His bag is heavy .....



2 Her bag is ..... .

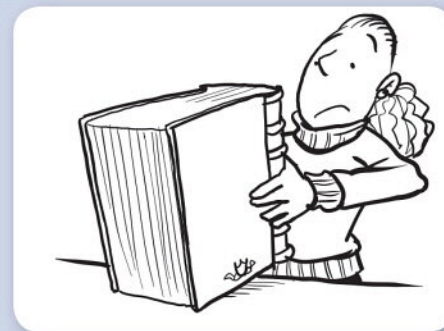

3 Her book is ..... .



4 His book is ..... .



5 The dog is ..... .

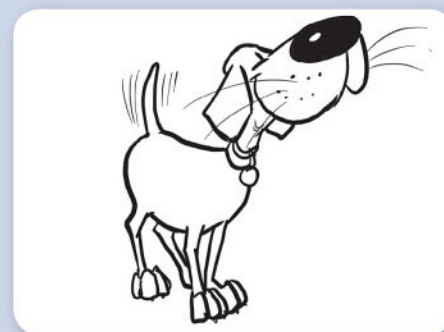

6 The dog is ..... .



## Grammar

1 Look at the picture. Fill in the blanks with the words below.

Her His My ~~Our~~ Their

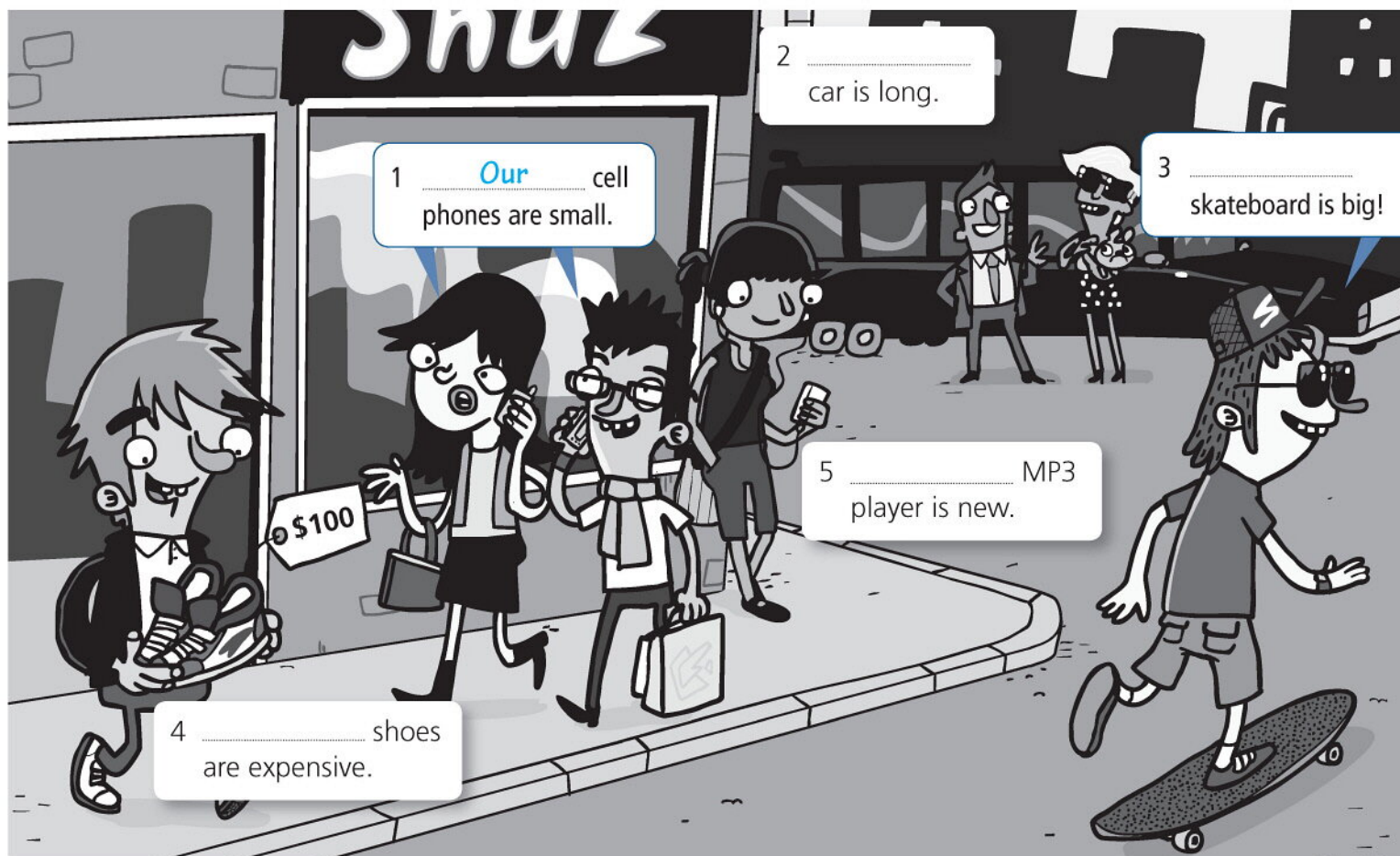

2 Circle the correct possessive adjective.

- Maria's friend: "She's from Mexico. Her / His name is Maria. She's my / your friend. Her / Their MP3 player is new. It's fantastic!"
- Jun and Aya's friend: "Jun and Aya are my / their friends. Her / Their cell phones are small. They're excellent!"
- Sergio's friend: "Hi, Sergio. Wow! Your / Our skateboard is big!"

3 Look at the pictures. Complete the sentences.

- Her name is Greta. Her shoes are new.
- \_\_\_\_\_ name is Felipe. \_\_\_\_\_ skateboard is cheap.
- \_\_\_\_\_ names are Jenny and Eric. \_\_\_\_\_ hair is long.
- \_\_\_\_\_ car is old. \_\_\_\_\_ price is \$50.





2

# Vocabulary

1 Look at the picture. Complete the crossword.

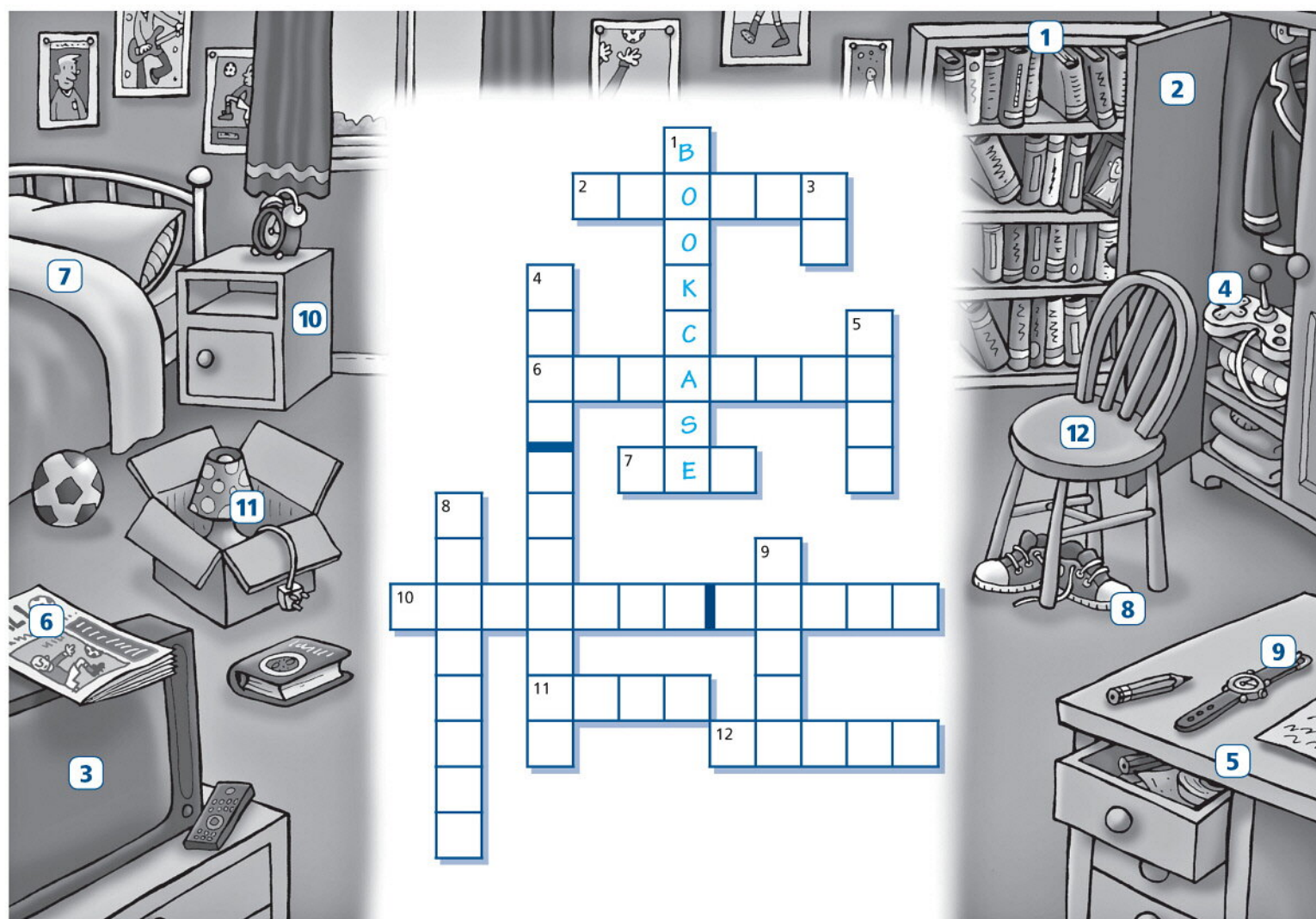

2 Look at the picture again. Fill in the blanks with *in*, *on*, or *under*.

- 1 The magazine is on the TV.
- 2 The sneakers are \_\_\_\_\_ the chair.
- 3 The game console is \_\_\_\_\_ the closet.
- 4 The watch is \_\_\_\_\_ the desk.
- 5 The lamp is \_\_\_\_\_ a box.

Extend your vocabulary

3 Label the pictures with the words below.

keyboard   monitor   mouse   mousepad   printer

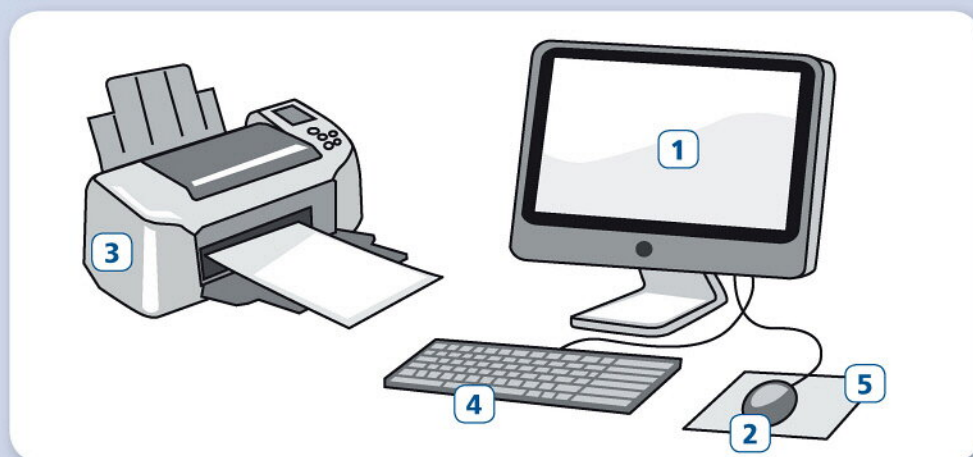

- 1 monitor
- 2 \_\_\_\_\_
- 3 \_\_\_\_\_
- 4 \_\_\_\_\_
- 5 \_\_\_\_\_



## Grammar

### 1 Circle the correct word.



1 This / That is my monitor.



2 These / Those are my magazines.



3 This / That is my MP3 player.



4 These / Those are my books.

### 2 Fill in the blanks with *this*, *that*, *these*, or *those*.



### 3 Write questions and answers.

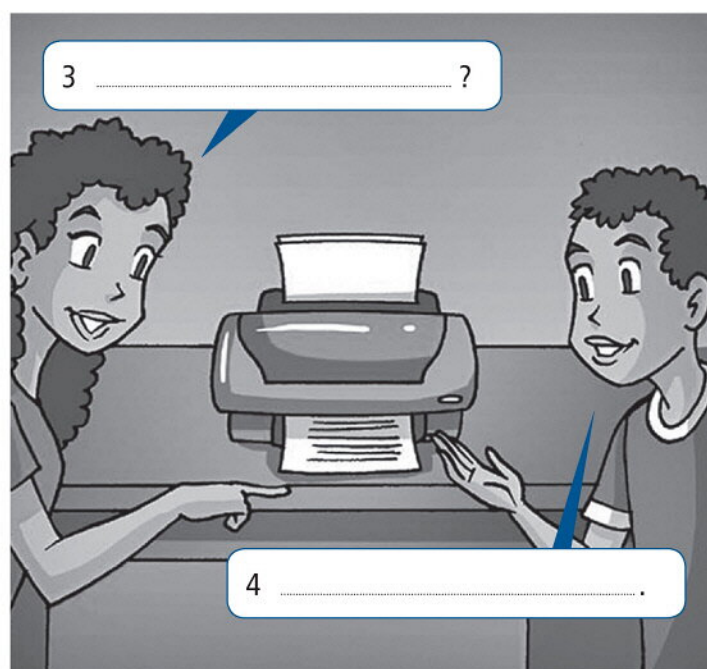



## 2

## Reading

1 Look at the pictures and read the speech bubbles quickly. Whose favorite thing is a laptop computer?



I'm Emilia and this is my favorite thing. It's my skateboard. It's long and black. Right now, it's under my bed in my bedroom. My friend's name is Aoki. Her favorite thing is her MP3 player. It's new and expensive.



I'm Bernardo. These are my favorite sneakers. They're black and white. They're new and expensive. Right now, they're in my closet at home. My friend's name is Jin. His favorite thing is his laptop computer. It's new. Right now, it's in his bag. His books are in his bag, too. His bag is heavy!

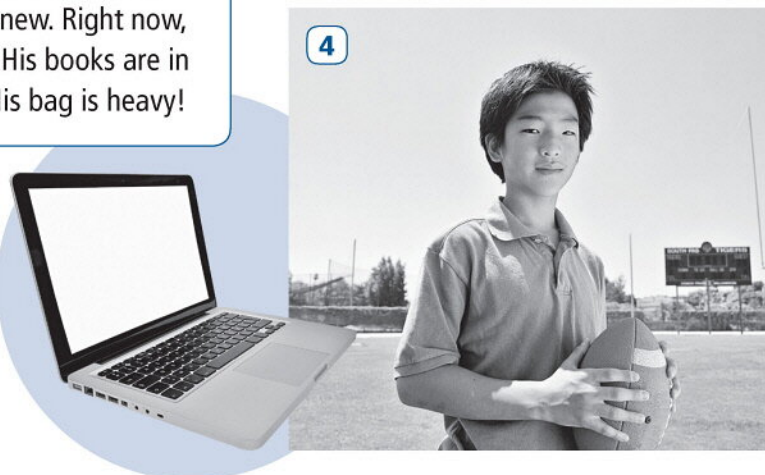

2 Read again. Circle the correct option.

- 1 Emilia's skateboard is under her bed / desk.      3 Bernardo's favorite sneakers are in his bag / closet.  
2 Aoki's MP3 player is new / cheap.                      4 Jin's bag is light / heavy.

3 Match the sentences with the things.

- 1 It's long and black.                                      a Bernardo's sneakers  
2 It's new.    b Jin's books  
3 They're new and expensive.                          c Jin's laptop computer  
4 They're in his bag.                                        d Emilia's skateboard

4 Answer the questions. Write sentences.

1 What color is Emilia's skateboard?

Emilia's skateboard is black

2 What is Jin's favorite thing?

.....

3 Who is Aoki's friend?

.....

4 Who is Bernardo's friend?

.....

5 What is in Jin's bag?

.....



## 3

## Favorite people

## Grammar reference

*be* (negative)

Negative	
Long Form	Short Form
I <b>am not</b> an actor.	I' <b>m not</b> an actor.
You <b>are not</b> an artist.	You <b>aren't</b> an artist.
He / She / It <b>is not</b> fantastic.	He / She / It <b>isn't</b> fantastic.
We <b>are not</b> models.	We <b>aren't</b> models.
You <b>are not</b> singers.	You <b>aren't</b> singers.
They <b>are not</b> athletes.	They <b>aren't</b> athletes.

We use *not* to make *be* (negative).

I'm not fifteen.

We aren't from Canada.

*be* (yes / no questions)

Question	Short answers
<b>Am I</b> a dancer?	Yes, <b>I am.</b> / No, <b>I'm not.</b>
<b>Are you</b> a singer?	Yes, <b>you are.</b> / No, <b>you aren't.</b>
<b>Is he</b> your father?	Yes, <b>he is.</b> / No, <b>he isn't.</b>
<b>Is she</b> your mother?	Yes, <b>she is.</b> / No, <b>she isn't.</b>
<b>Is it</b> your house?	Yes, <b>it is.</b> / No, <b>it isn't.</b>
<b>Are we</b> friends?	Yes, <b>we are.</b> / No, <b>we aren't.</b>
<b>Are you</b> brothers?	Yes, <b>you are.</b> / No, <b>you aren't.</b>
<b>Are they</b> models?	Yes, <b>they are.</b> / No, <b>they aren't.</b>

We form *yes / no* questions with *be* + subject.

They are happy. → Are they happy?

## Word list

## Jobs

actor  
 artist  
 athlete  
 dancer  
 doctor  
 model  
 singer  
 skateboarder  
 soccer player  
 writer

## Family

brother  
 father  
 grandfather  
 grandmother  
 grandparents  
 mother  
 parents  
 sister



## Vocabulary

1 Unscramble the jobs and complete the puzzle.

- 1 risatt
- 2 codtro
- 3 narced
- 4 tesoardkaber
- 5 riwret
- 6 lomed
- 7 tlahete
- 8 nsigre
- 9 toacr

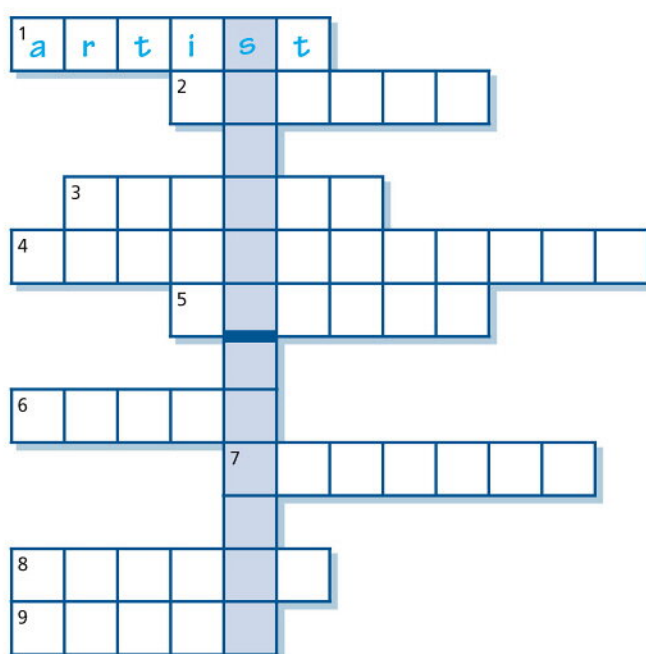

What's the mystery word? .....

2 Write a or an.

- 1 an actor      3 ..... dancer      5 ..... soccer player      7 ..... singer      9 ..... athlete
- 2 ..... doctor      4 ..... artist      6 ..... model      8 ..... skateboarder      10 ..... writer

3 Match the people with the words below.

- builder       guitarist       police officers       taxi driver       TV reporter



Extend your vocabulary



## Grammar



NAME	Simon	Luis	Debra	Chen	Asa	Cathy
NATIONALITY	British	Brazilian	British	Chinese	Nigerian	Australian
AGE	32	28	30	18	18	22
JOB	actor	doctor	doctor	student	model	police officer

**1** Look at the chart. Put the words in order to make sentences.

- Debra / not / French / is Debra is not French .....
- not / police officer / a / Simon / is .....
- Russia / I / from / not / am "....." (Chen)
- eighteen / not / is / Luis .....
- are / students / We / not "....." (Simon and Cathy)
- models / not / Debra and Luis / are .....

**2** Fill in the blanks with *isn't* or *aren't*.

- Luis isn't a student.
- Cathy ..... from the United Kingdom.
- Simon and Asa ..... doctors.
- "We ..... sixteen. We're eighteen!" (Asa and Chen)
- Debra ..... twenty. She's thirty.
- "We ..... singers. We're doctors!" (Luis and Debra)

**3** These sentences are wrong. Write the correct sentences. Use subject pronouns.

- Cathy is a doctor.  
She isn't a doctor ..... She's a police officer .....
- Chen is Russian.  
He .....
- Luis and Debra are actors.  
They .....
- Asa is sixteen.  
She .....
- Simon and Debra are from France.  
They .....



## Vocabulary

### 1 Look at Leo's family tree. Circle the correct word.

- Peter and Alice are Leo's parents / grandparents.
- Mary and Michelle are George's sisters / brothers.
- Simon is Michelle's grandfather / father.
- Lizzie is Mary's grandmother / mother.
- Leo is Michelle's brother / sister.
- Alice is George's grandmother / grandparents.



Peter + Alice



Simon + Lizzie

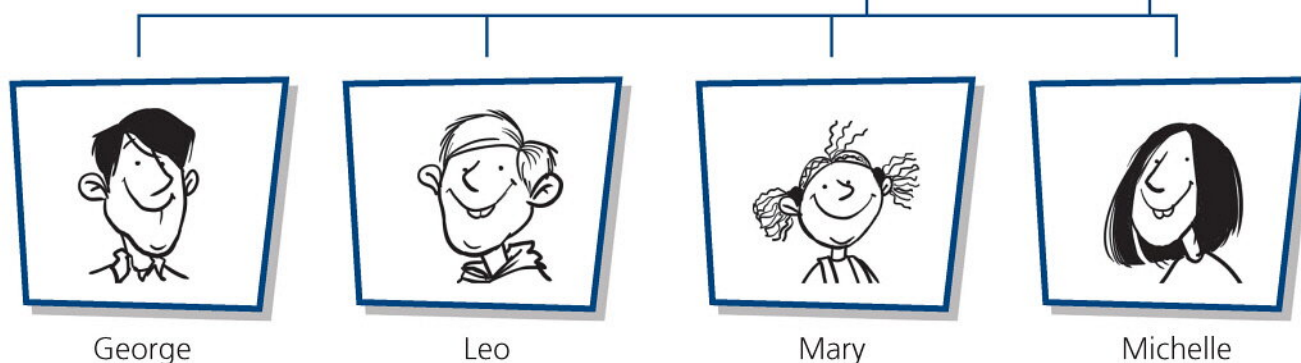

### 2 Fill in the blanks with the correct word from exercise 1.

- Simon and Lizzie are Michelle's parents.
- Peter is Simon's .....
- Michelle is Mary's .....
- Lizzie is Leo's .....
- George and Leo are Mary's .....
- Peter is Mary's .....

### 3 These are some more people in Leo's family. Fill in the blanks with the words below.

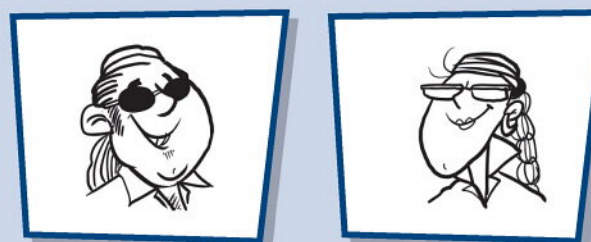

Simon + Lizzie ——— Tom                      Jenny



Katie

aunt children cousin daughters sons uncle

- Jenny is George's aunt.
- George, Leo, Michelle, and Mary are Simon and Lizzie's .....
- Tom is Michelle's .....
- Katie is Mary's .....
- Mary and Michelle are Simon and Lizzie's .....
- George and Leo are Simon and Lizzie's .....



## Grammar

1 Look at the pictures. Fill in the blanks with *is*, *isn't*, *are*, or *aren't*.

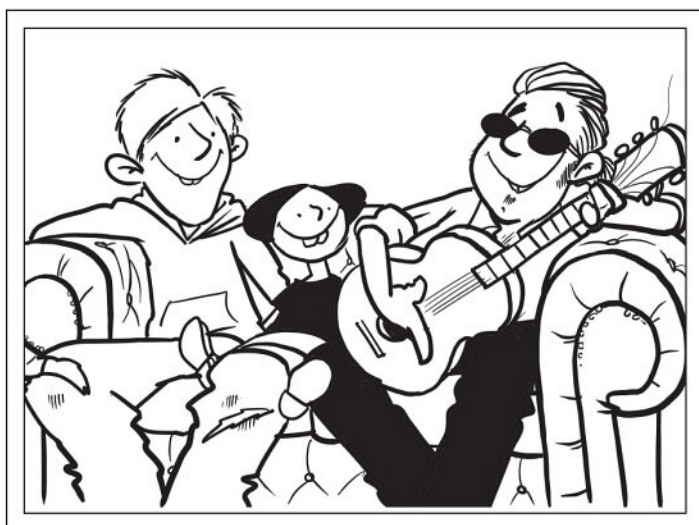

Nick: (1) **is** she your sister?

George: No, she (2) ..... She's my cousin!

Nick: (3) ..... he your father?

George: No, he (4) ..... He's my uncle!

Nick: (5) ..... he a guitarist?

George: Yes, he (6) ..... He's cool!



Nick: (7) ..... they your parents?

George: No, they (8) ..... They're my grandparents!

Nick: (9) ..... they from the United Kingdom?

George: Yes, they (10) ..... They're from London.

2 Write questions and answers about the pictures.

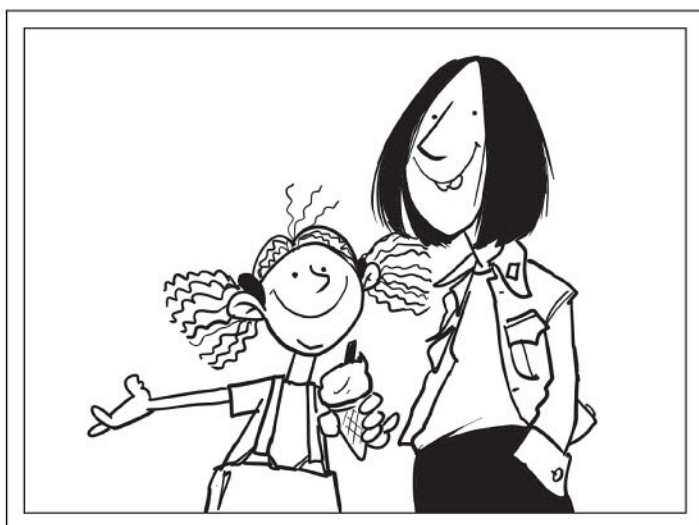

(1) **Are they** ..... George's cousins?

No, (2) **they aren't** ..... They're his sisters.

(3) ..... students?

Yes, (4) .....



(5) ..... George's father?

Yes, (6) ..... He's a writer.

(7) ..... George's mother?

Yes, (8) .....

(9) ..... a teacher?

No, (10) ..... She's a police officer!

3 Answer the questions. Use short answers. Write a correct sentence.

1 Are you a teacher? **No, I'm not** ..... **I'm a student** .....

2 Are you from the United Kingdom? .....

3 Are you thirty years old? .....



## Reading

1 Look at the names in the articles. What do you know about these people?



### *Demi* LOVATO

Demi Lovato is an actor, singer, model, and guitarist. She's from Dallas, in the U.S. Demi's mother is a singer, too. Her name is Dianna. Demi's father's name is Patrick. Her sisters' names are Dallas and Madison. They are actors, too. Demi's birthday is August 20<sup>th</sup>.



### Adele

Adele is from the U.K. She's a singer and songwriter. Adele's full name is Adele Laurie Blue Adkins. Her birthday is May 5. Her mother's name is Penny Adkins. She isn't famous.



### Zezé Di Camargo e Luciano

Zezé Di Camargo and Luciano are brothers. Zezé's real name is Mirosmar José de Camargo and Luciano's real name is Welton David de Camargo. They're from Brazil and they're famous singers. Luciano's sons are Nathan and Wesley. His daughters are Isabella and Helena. Zezé's daughter is famous, too. She's a singer. Her name is Wanessa Camargo.

2 Read the articles. Circle the correct option.

- 1 Dianna is Demi's mother / sister.
- 2 Patrick is Demi's father / brother.
- 3 Adele is a dancer / singer.
- 4 Zezé is / isn't Luciano's brother.

3 Read again. Write the names.

- 1 He's Nathan's father. Luciano
- 2 She's British. \_\_\_\_\_
- 3 She's Demi and Madison's sister.  
\_\_\_\_\_
- 4 He has two sons and two daughters. \_\_\_\_\_
- 5 They are Brazilian. \_\_\_\_\_
- 6 Her birthday is May 5. \_\_\_\_\_

4 Correct the sentences. Use short forms.

- 1 Patrick is Demi's brother. He's Demi's father
- 2 Dallas and Madison are Demi's daughters. \_\_\_\_\_
- 3 Adele is Australian. \_\_\_\_\_
- 4 Penny Adkins is Luciano's daughter. \_\_\_\_\_
- 5 Zezé Di Camargo and Luciano aren't brothers. \_\_\_\_\_
- 6 Isabella and Wesley are Luciano's parents. \_\_\_\_\_
- 7 Wanessa is Zezé's son. \_\_\_\_\_



## 4

## Favorite places

## Grammar reference

## there is / there are

Affirmative	
Singular	Plural
There is a mountain.	There are mountains.
There's a river.	There are three rivers.

Questions and short answers	
Singular	Plural
Is there a waterfall?	Are there any birds?
Yes, there is.	Yes, there are.
No, there isn't.	No, there aren't.

We use *There is* + *a / an* with singular nouns.

There's a lake in my country.

We use *There are* with plural nouns.

There are beaches in Patagonia.





We use *Is there* + *a / an ... ?* with singular nouns.

Is there a mountain? Yes, there is.

We use *Are there any ...?* with plural nouns.

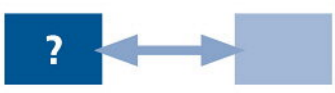
Are there any tigers? No, there aren't.

## Prepositions of place

Questions and answers	
Where is the sports store? It's <b>across from</b> the bookstore.	
Where are the restrooms? They're <b>next to</b> the bookstore.	
Where is the cybercafé? It's <b>between</b> the sports store and the movie theater.	
Where is the bus stop? It's <b>in front of</b> the shopping mall.	

We use *Where is...?* or *Where are...?* to ask about position.

Where is the shopping mall?

Where are the movie theaters?

We use prepositions to talk about position.

It's across from the bookstore.

They're in front of the shopping mall.

See Student Book unit 2, page 22 for more prepositions of place.

## Word list

## Nature

beach  
bird  
butterfly  
forest  
fox  
lake  
monkey  
mountain  
river  
waterfall

## Places in a town

bookstore  
bus stop  
clothes store  
cybercafé  
fast food restaurant  
movie theater  
restrooms  
sports store



## 4

## Vocabulary

## 1 Unscramble the words.

1 trosef forest      3 omuninat .....      5 hecab .....

2 elka .....      4 verri .....

## 2 Fill in the blanks with the singular or plural of the words.



1 Are they birds?  
No! They're butterflies.

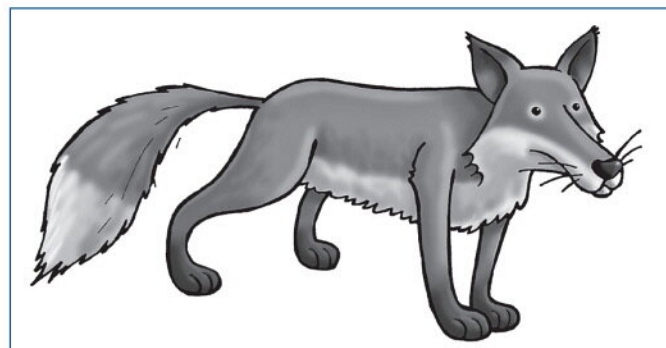

2 Is it a monkey?  
No! It's a .....

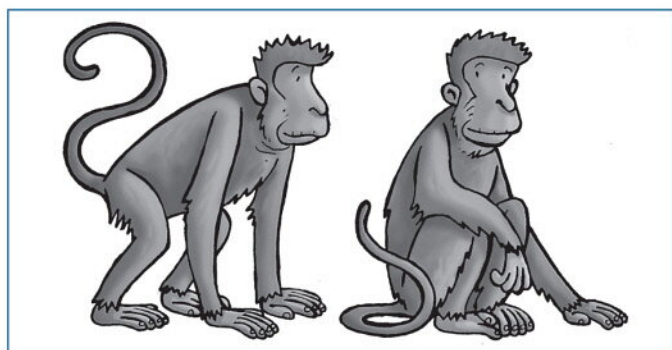

3 Are they foxes?  
No! They're .....



4 Is it a butterfly?  
No! It's a .....

## 3 Look at the picture. Fill in the blanks with the plurals of the words below.

eat   chicken   cow   dog   goat

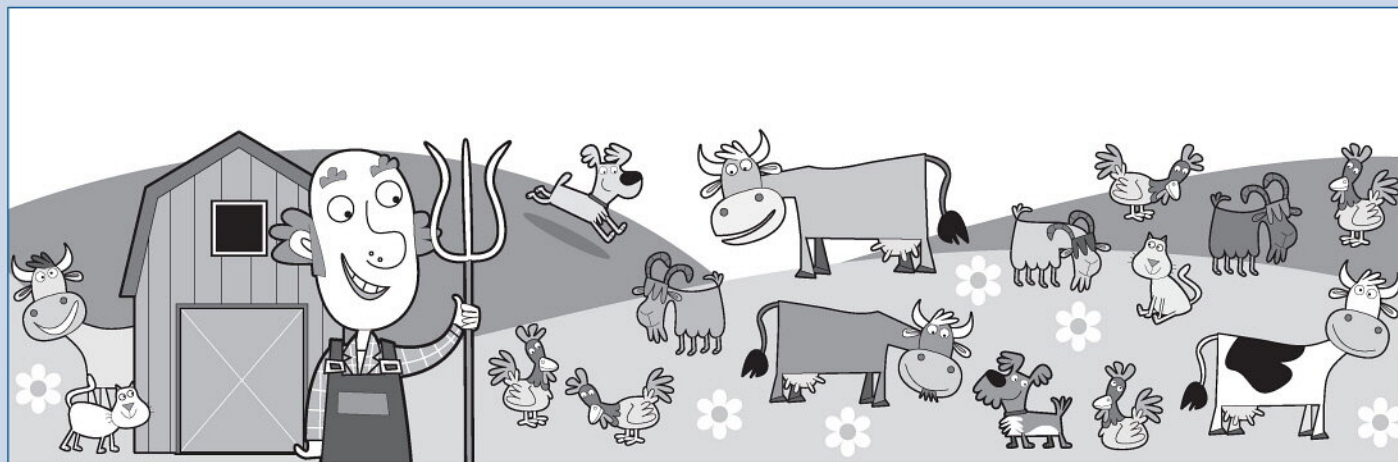

1 There are two cats .....      3 There are three .....      5 There are five .....

2 There are two .....      4 There are four .....



## Grammar

### 1 Circle the correct word.

- 1 Is / Are there a forest?    3 Is / Are there any mountains?    5 Is / Are there any waterfalls?  
 2 There is / are beaches.    4 There is / are a bear.    6 There is / are a river.

### 2 Look at the postcard. Fill in the blanks with *There is, there is, There are, or there are*.

Hi Dan!

POSTCARD

Rocky Mountain National Park is fantastic!

(1) There are big mountains, and

(2) ..... a beautiful lake.

I'm in the forest right now, and (3) .....

..... bears in the forest!

(4) ..... a small river,

but there aren't any beaches.

Bye!

Rosa



### 3 Look at Rosa's photos from her vacation. Complete the conversation.



Dan: (1) Is there a forest in the park?

Rosa: Yes, (2) ..... And

(3) ..... bears in the forest. They're beautiful!

Rosa: Look at the picture! (4) .....

..... goats in the mountains.

Dan: (5) ..... any cows or chickens?

Rosa: No, (6) .....

Dan: (7) ..... any beaches?

Rosa: No, (8) .....

Dan: (9) ..... a river?

Rosa: Yes, (10) ..... It's cold in the river!





4

# Vocabulary

1 Fill in the blanks with the words below

book bus cyber rest restaurant store store theater

- 1 bus stop      3 \_\_\_\_\_ café      5 movie \_\_\_\_\_      7 \_\_\_\_\_ rooms  
 2 clothes \_\_\_\_\_      4 fast food \_\_\_\_\_      6 \_\_\_\_\_ store      8 sports \_\_\_\_\_

2 Where are they? Fill in the blanks with the correct words.

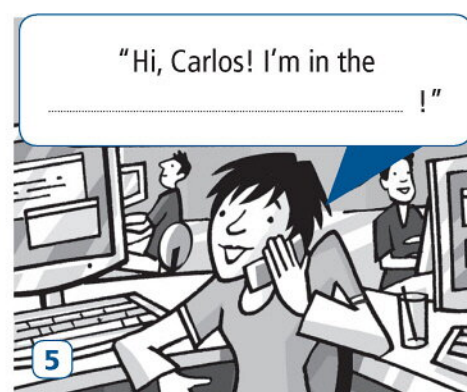
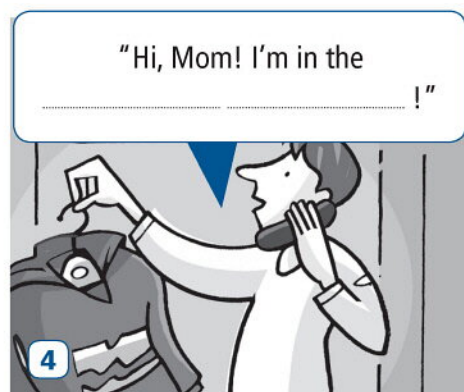
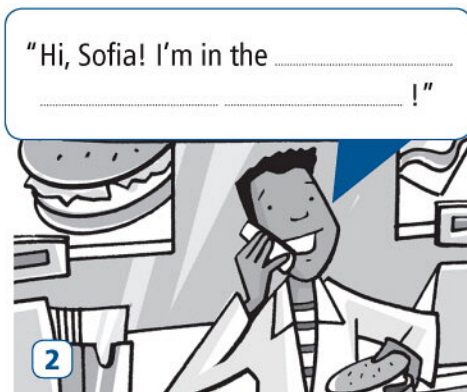

3 Match the pictures with the words below.

- 4 fire station     hospital     library     police station     school

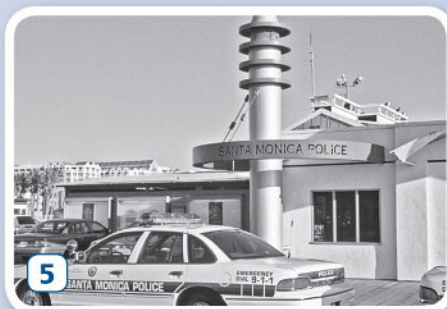
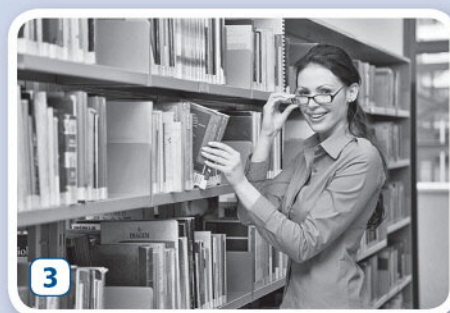

Extend your vocabulary



## Grammar

### 1 Look at the map. Circle the correct preposition.

- The cybercafé is across from / next to the clothes store.
- The restrooms are between / across from the movie theater and the cybercafé.
- The hospital is across from / next to the fire station.
- The bus stop is between / in front of the sports store.
- The movie theater is next to / in front of the restrooms.

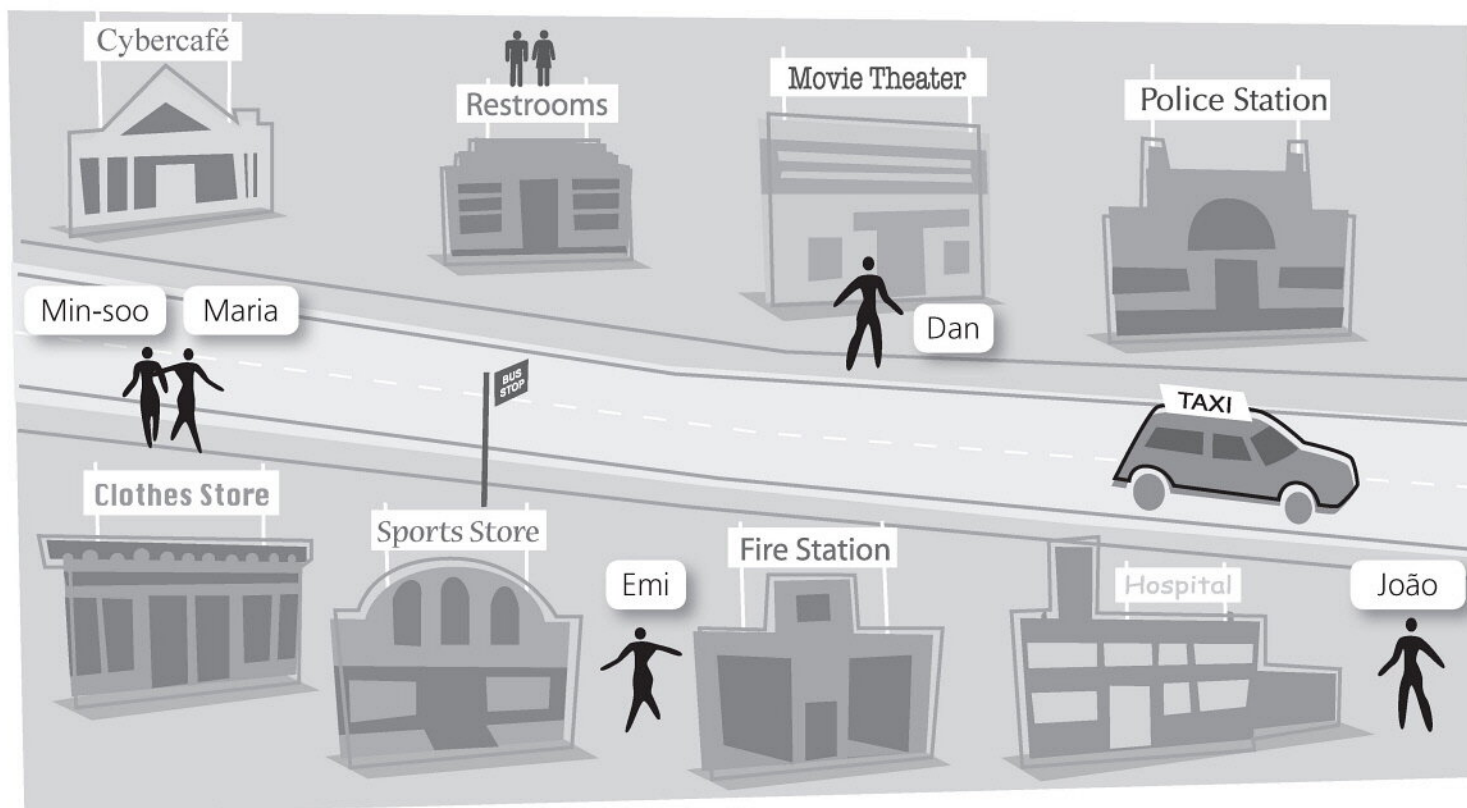

### 2 Look at the map. Fill in the blanks with the correct preposition.

- João is next to the hospital.
- Min-soo and Maria are ..... the cybercafé.
- Dan is ..... the movie theater.
- Emi is ..... the sports store and the fire station.
- The clothes store is ..... the sports store.

### 3 Complete the questions and answers about the map.

- Where's the taxi?  
It's in front of the police station.
- ..... the police station?  
It's ..... the movie theater.
- ..... Min-soo and Maria?  
They're ..... the clothes store.
- ..... the fire station?  
..... the sports store and the hospital.
- ..... the movie theater?  
..... the fire station.



## 4

## Reading

1 Look at the picture. Do you think Casa Bonita is ... ?

- a a movie theater      b a shopping mall      c a restaurant

### Casa Bonita

Casa Bonita is a famous Mexican restaurant in Denver in the U.S. It's in a shopping mall, but it isn't a fast food restaurant. Inside Casa Bonita, there's a small forest. There's a small lake, too. There are tables and chairs between the forest and the lake. Next to the lake, there's a very small mountain. There's a waterfall, too. It's across from the tables and chairs.

The forest and the lake are beautiful. But there aren't any animals or birds or butterflies in Casa Bonita. The trees and the mountain aren't real. They're plastic. But the food isn't plastic. It's good!

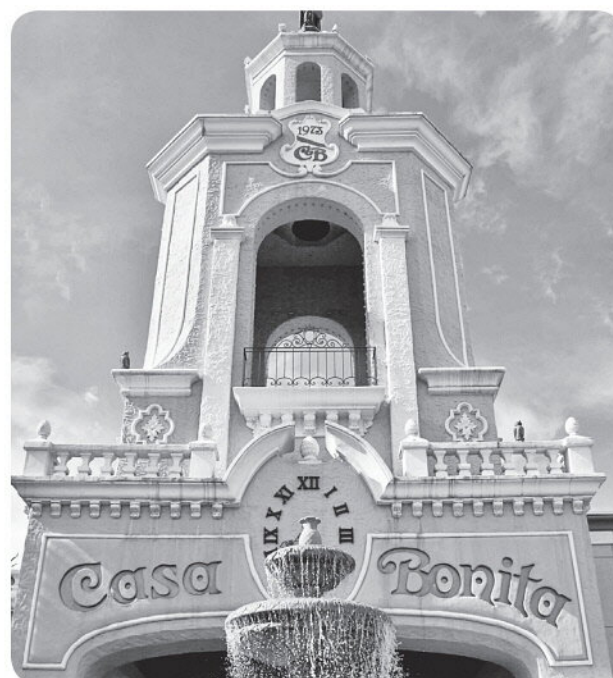

2 Read the review. Circle the correct option.

- 1 Casa Bonita is in a movie theater / shopping mall.      3 There are / aren't butterflies in Casa Bonita.  
2 Casa Bonita is / isn't a fast food restaurant.      4 There's a lake / river in the restaurant.

3 Read again. Match the questions and answers.

- 1 Is there a waterfall in Casa Bonita?      a Yes, there are.  
2 Are there any tables and chairs in Casa Bonita?      b Yes, there is.  
3 Are there any animals in Casa Bonita?      c Yes, there is.  
4 Is there a plastic forest in Casa Bonita?      d No, there isn't.  
5 Is there a real mountain in Casa Bonita?      e No, there aren't.

4 Answer the questions. Use short forms.

- 1 Is there a big forest in Casa Bonita?  
No, there isn't      There's a small forest
- 2 Is there a mountain?  
Yes, ..... next to the lake.
- 3 Is there a beach across from the tables and chairs?  
.....
- 4 Are there any tables and chairs?  
.....
- 5 Are the trees and the mountains real?  
.....



## 5

## Fun and games

## Grammar reference

## can

Affirmative			Negative		
I	<b>can</b>	run fast.	I	<b>can't</b>	run fast.
You	<b>can</b>	swim.	You	<b>can't</b>	swim.
He / She / It	<b>can</b>	jump high.	He / She / It	<b>can't</b>	jump high.
We	<b>can</b>	dance.	We	<b>can't</b>	dance.
You	<b>can</b>	ski.	You	<b>can't</b>	ski.
They	<b>can</b>	ice-skate.	They	<b>can't</b>	ice-skate.

Questions and short answers			
<b>Can</b>	I	swim?	Yes, I <b>can</b> . / No, I <b>can't</b> .
<b>Can</b>	you	run fast?	Yes, you <b>can</b> . / No, you <b>can't</b> .
<b>Can</b>	he / she / it	dance?	Yes, he / she / it <b>can</b> . / No, he / she / it <b>can't</b> .
<b>Can</b>	we	surf?	Yes, we <b>can</b> . / No, we <b>can't</b> .
<b>Can</b>	you	ski?	Yes, you <b>can</b> . / No, you <b>can't</b> .
<b>Can</b>	they	dive?	Yes, they <b>can</b> . / No, they <b>can't</b> .

We form sentences with *can / can't* + infinitive.

I can surf.

We can read.

He can't dance.

We form questions with *can* + subject.

I can sing. → Can I sing?

## Imperatives

Affirmative	Negative
<b>Run!</b>	<b>Don't run!</b>
<b>Pass the ball!</b>	<b>Don't pass the ball!</b>

We use imperatives to give instructions.

Throw the ball!

We form the negative with *Don't* + verb.

Don't touch.

## Word list

## Sports activities

dance  
dive  
ice-skate  
jump high  
play basketball  
ride a horse  
run fast  
ski  
surf  
swim

## Sports verbs

hit  
kick  
pass  
throw  
touch  
walk



5

### Vocabulary

1 Find five activities in the word snake. Then write the words.



- 1 dance
- 2 \_\_\_\_\_
- 3 \_\_\_\_\_
- 4 \_\_\_\_\_
- 5 \_\_\_\_\_

2 Match the words.

- |        |   |              |
|--------|---|--------------|
| 1 ride | — | a basketball |
| 2 run  | — | b a horse    |
| 3 play |   | c fast       |
| 4 jump |   | d skate      |
| 5 ice- |   | e high       |

3 Look at the pictures. What can these people do? Label the pictures with the words below.

cook   draw   drive   play the guitar   **sing**   speak French



1 sing



2 \_\_\_\_\_



3 \_\_\_\_\_



4 \_\_\_\_\_



5 \_\_\_\_\_



6 \_\_\_\_\_

Extend your vocabulary



## Grammar

1 Look at the chart. Circle the correct word.

	Alicia	Mario	Eun-ju
swim	✓	✓	✗
draw	✗	✗	✓
speak Spanish	✓	✗	✓
cook	✗	✓	✓
ride a horse	✓	✓	✗

- 1 Alicia can / can't speak Spanish.
- 2 Eun-ju can / can't cook.
- 3 Mario can / can't draw.
- 4 Alicia can / can't cook.

2 Look at the chart. Fill in the blanks with *can* or *can't*.

- 1 Mario can cook.
- 2 Eun-ju \_\_\_\_\_ ride a horse.
- 3 Alicia and Mario \_\_\_\_\_ swim.
- 4 Alicia \_\_\_\_\_ draw.

3 Write questions and answers about Alicia, Mario, and Eun-ju.

Eun-ju

- 1 Can she draw? Yes, she can.
- 2 \_\_\_\_\_ swim? No, \_\_\_\_\_.

Alicia and Mario

- 3 \_\_\_\_\_ they ride a horse? Yes, \_\_\_\_\_.
- 4 \_\_\_\_\_ draw? \_\_\_\_\_, \_\_\_\_\_.

Mario

- 5 \_\_\_\_\_ speak Spanish? \_\_\_\_\_, \_\_\_\_\_.
- 6 \_\_\_\_\_ cook? \_\_\_\_\_, \_\_\_\_\_.



5

Vocabulary

1 Circle the six sports words in the wordsearch. Then write the words.

C	R	K	I	C	K	E
T	O	U	C	H	C	S
A	H	I	T	N	W	I
P	O	R	W	L	A	C
L	A	T	O	R	L	N
E	B	S	R	W	K	S
N	I	O	S	A	R	L

- 1 hit
- 2 p\_ \_ \_
- 3 w\_ \_ \_
- 4 k\_ \_ \_
- 5 t\_ \_ \_ w
- 6 t\_ \_ \_ \_

2 Match the words 1-6 in exercise 1 with the pictures a-f below.

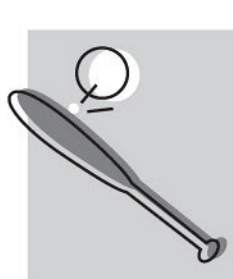

a 1

b \_\_\_\_\_

c \_\_\_\_\_

d \_\_\_\_\_

e \_\_\_\_\_

f \_\_\_\_\_

3 Match the pictures with the instructions below.

- 4 Catch the ball!  Dive into the water!  Don't drop the ball!  Don't fall over!  Stand up!

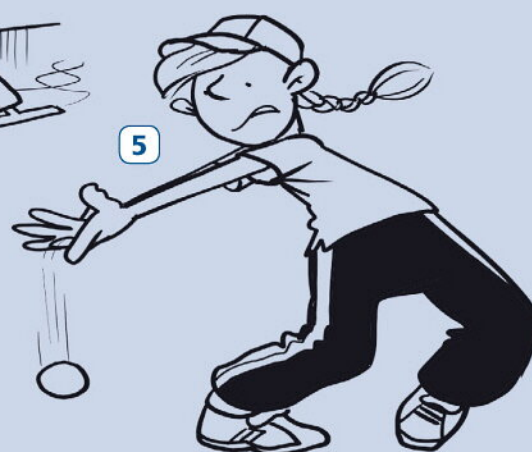
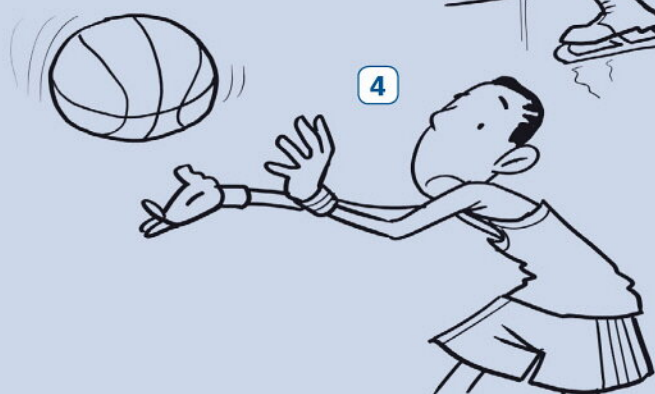
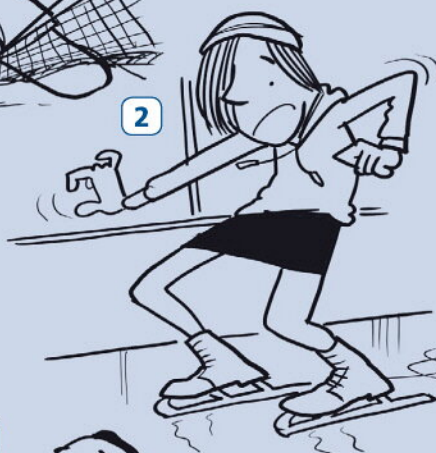
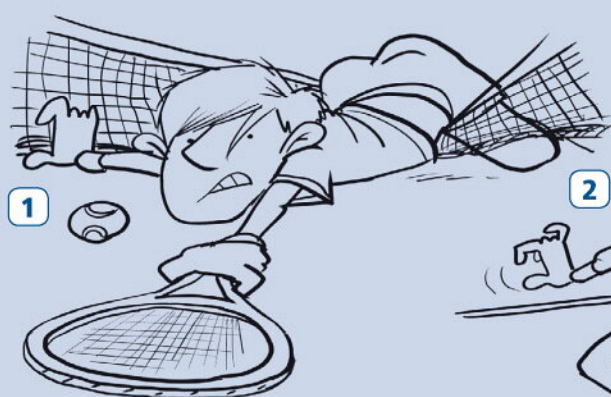

Extend your vocabulary



## Grammar

### 1 Circle the correct instruction for the place.

- 1 Ice-skating rink: Fall over! / Don't fall over!
- 2 Classroom: Listen to the teacher! / Don't listen to the teacher!
- 3 Baseball game: Drop the ball! / Don't drop the ball!
- 4 English lesson: Speak English! / Don't speak English!
- 5 Tennis match: Hit the ball! / Don't hit the ball!

### 2 Put the words in order to make sentences.

- 1 the / classroom / Don't / in / run Don't run in the classroom !
- 2 brother / Don't / your / hit \_\_\_\_\_ !
- 3 drive / fast / Don't \_\_\_\_\_ !
- 4 touch / glass / Don't / the \_\_\_\_\_ !
- 5 in / Don't / lake / swim / the \_\_\_\_\_ !

### 3 Look at the pictures. Write instructions.

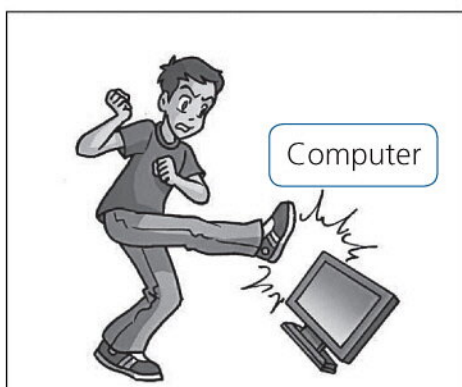

1 Don't kick the computer .

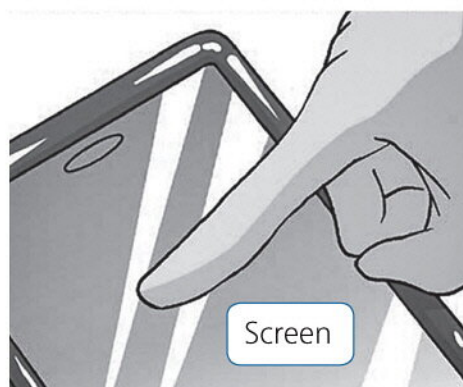

2 \_\_\_\_\_ .  
\_\_\_\_\_ .

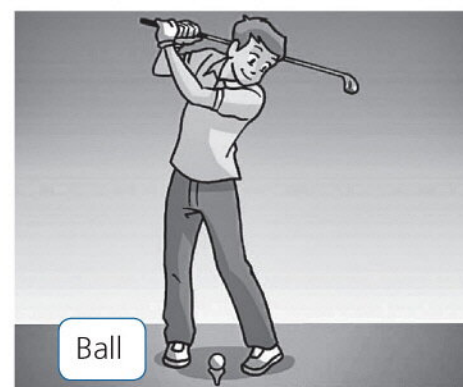

3 \_\_\_\_\_ .  
\_\_\_\_\_ .



4 \_\_\_\_\_ .  
\_\_\_\_\_ .



5 \_\_\_\_\_ .



## Reading

### 1 Scan the interview. Answer the questions.

- 1 Is Calvin famous? .....
- 2 How fast can Calvin fly? .....
- 3 What is the price of a wingsuit? .....



**Where is he from?**  
He's from the U.S.

**Who is Calvin?**  
Calvin's famous. You can see him on TV, in movies, and on the Internet. But he isn't an actor or a singer – he can't act and he can't sing.

**Why is he famous?**  
Calvin is famous because he can fly.

**Can he really fly?**  
Yes, he can fly! He jumps from airplanes and he jumps from mountains. He wears a special suit – a wingsuit.

**Can he fly fast?**  
Yes, he can. Calvin can fly 200 kilometers per hour in his wingsuit! Calvin is also a pilot. He can fly in an airplane, too.

**Can I buy a wingsuit?**  
Yes, you can. You can buy a wingsuit on the Internet. Its price is about \$250. But please – have wingsuit lessons first!

# CALVIN CAN FLY!

### 2 Read the interview. Circle the correct option.

- 1 Calvin is from the U.S. / Spain.
- 2 He can act / fly with a special suit.
- 3 He jumps from mountains / waterfalls.
- 4 There are / aren't wingsuit stores on the Internet.

### 3 Read again. Complete the sentences.

- 1 Calvin is on TV and in movies.
- 2 Calvin can't act or .....
- 3 Calvin jumps from mountains and .....
- 4 Calvin can fly in an airplane because he's a .....

### 4 These sentences are wrong. Write a correct sentence.

- 1 Calvin is Australian.  
He isn't Australian. He's American
- 2 Calvin is a singer.  
.....
- 3 He can fly in his fliesuit.  
.....
- 4 He can fly 300 kilometers per hour.  
.....



## 6

## Work and play

## Grammar reference

## Simple present (affirmative)

Affirmative		
I	<b>go</b> to school	at eight o'clock.
You	<b>get</b> up	at seven thirty.
We	<b>have</b> lunch	at twelve thirty.
You	<b>watch</b> TV	in the evening.
They	<b>finish</b> classes	at three o'clock.

We use the simple present to talk about routines and habits.

I start school at eight o'clock.

Simple present (*he / she / it*)

Affirmative	
<b>add -s</b>	
He <b>thinks</b> science is cool.	
She <b>likes</b> math.	
It <b>starts</b> at 9 o'clock.	
<b>add -es after -o, -x, -sh, or -ch</b>	
He <b>goes</b> to school on Saturdays.	
She <b>does</b> her homework in the morning.	
It <b>finishes</b> at nine thirty.	
<b>change -y to -i and add -es</b>	
He / She / It <b>studies</b> English.	
<b>irregular</b>	
He / She / It <b>has</b> breakfast in the morning.	

We add -s to the verb with *he / she / it*.

He starts school at six o'clock.

We add -es after -o, -x, -sh, and -ch.

He goes to the office.

It finishes at ten o'clock.

Some verbs are irregular.

She has breakfast at eight o'clock.

## Word list

## Daily routines

do my homework  
 finish classes  
 get up  
 go to bed  
 go to school  
 have breakfast  
 have dinner  
 have lunch  
 start classes  
 watch TV

## School subjects

art  
 computer science  
 English  
 geography  
 history  
 math  
 music  
 P.E.  
 science  
 technology



## Vocabulary

### 1 Unscramble the verbs.

- 1 o d y m mehokrow do my homework
- 2 h i s f i n s s e s a l c \_\_\_\_\_
- 3 t e g p u \_\_\_\_\_
- 4 o g o t d e b \_\_\_\_\_
- 5 o g o t l o o s c h \_\_\_\_\_

- 6 v e h a s t a f k r e a b \_\_\_\_\_
- 7 a v e h r e d i n n \_\_\_\_\_
- 8 h e a v c h u l n \_\_\_\_\_
- 9 t r a s t c e s l a s s \_\_\_\_\_
- 10 h a w t c V T \_\_\_\_\_

### 2 Complete the crossword.

My day

- 7:00: get (5) \_\_\_\_\_
- 7:15: have (7) \_\_\_\_\_
- 7:45: go to (3) \_\_\_\_\_
- 8:30: start (1) \_\_\_\_\_
- 12:30: have (4) \_\_\_\_\_
- 4:00: finish (2) \_\_\_\_\_
- 6:00: have (10) \_\_\_\_\_
- 7:00: do my (6) \_\_\_\_\_
- 9:00: watch (8) \_\_\_\_\_
- 10:30: go to (9) \_\_\_\_\_

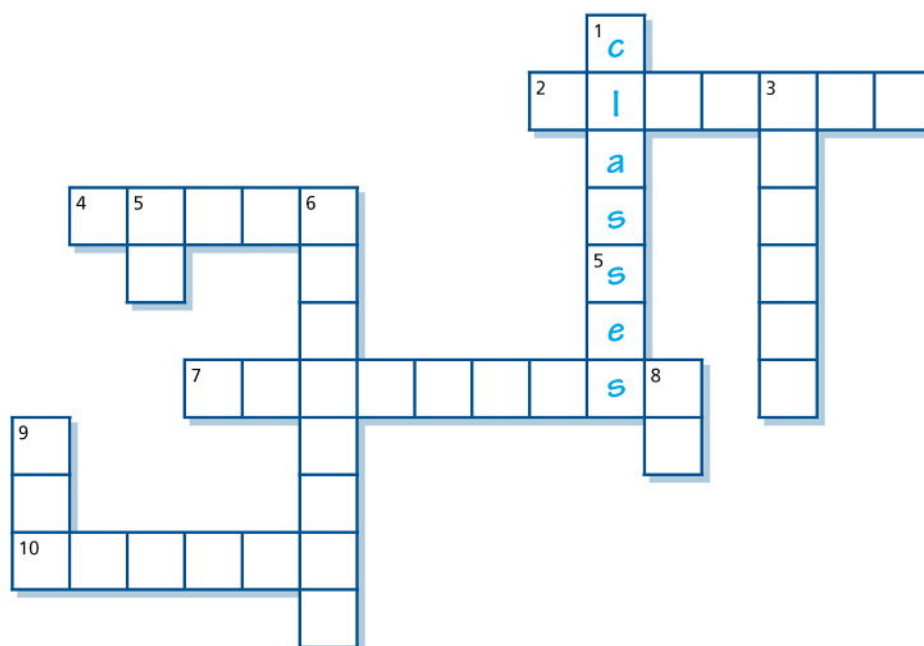

### 3 Label the pictures with the words below.

buy a sandwich    listen to music    take the bus    ~~take a shower~~    visit my grandparents



1 take a shower

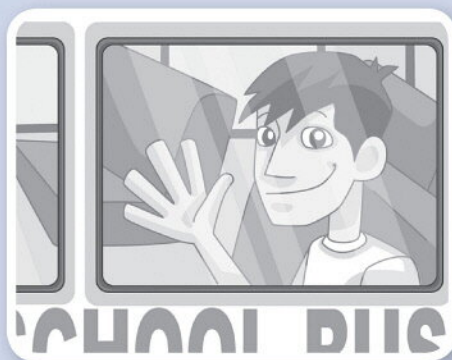

2 \_\_\_\_\_

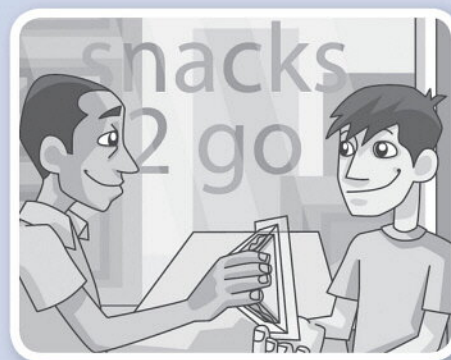

3 \_\_\_\_\_



4 \_\_\_\_\_

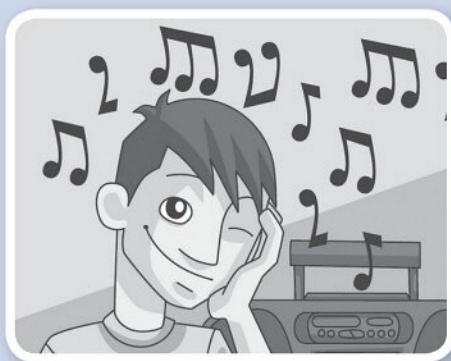

5 \_\_\_\_\_



## Grammar

### 1 Circle the correct word.

- I have / watch TV in the evening.
- We go / have breakfast at seven thirty in the morning.
- I take / go the bus to school at eight o'clock in the morning.
- I am / go to bed at eleven o'clock.
- I take / do a shower in the morning.
- We get / do our homework after school.

### 2 Fill in the blanks with *at* or *in*.

- I listen to music in the evening.
- We start classes ..... eight o'clock.
- You go to bed ..... ten thirty.
- They get up at five o'clock ..... the morning.
- I go to school ..... eight thirty.
- I finish classes at three o'clock ..... the afternoon.

### 3 Write sentences about the pictures. Use the simple present.



1 We have lunch at twelve thirty .....



2 I .....



3 They go .....



4 We ..... classes .....



5 I .....



6 I listen to music .....



## Vocabulary

### 1 Fill in the blanks in the school subjects.

- |                     |                                 |
|---------------------|---------------------------------|
| 1 m <u>a</u> t h    | 6 m _ s _ c                     |
| 2 a _ t             | 7 E _ _ l i _ _                 |
| 3 g _ o _ r a _ _ y | 8 c _ m _ _ t _ r s _ i _ n c _ |
| 4 _ i s _ o r y     | 9 t _ c h n _ _ _ g _           |
| 5 P _ .             | 10 _ c i _ n c _                |

### 2 Match the school subjects in exercise 1 with the pictures below.

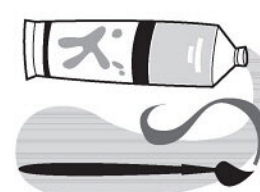
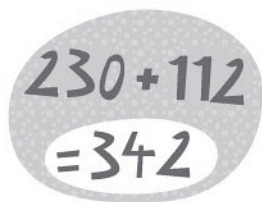
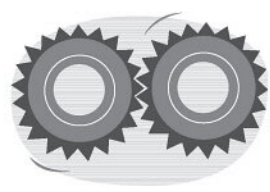

a 9

b \_\_\_\_\_

c \_\_\_\_\_

d \_\_\_\_\_

e \_\_\_\_\_

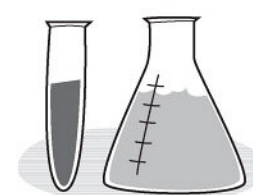

f \_\_\_\_\_

g \_\_\_\_\_

h \_\_\_\_\_

i \_\_\_\_\_

j \_\_\_\_\_

### 3 Label the pictures with the words below.

band choir drama karate Spanish



1 band

2 \_\_\_\_\_

3 \_\_\_\_\_



4 \_\_\_\_\_

5 \_\_\_\_\_







## Grammar

### 1 Circle the correct words in these sentences.

- 1 Daniel and Alice are brother and sister. They **get** / **gets** up at six thirty in the morning.
- 2 They **have** / **has** breakfast at seven o'clock.
- 3 Alice **study** / **studies** science and history in the morning.
- 4 Alice **start** / **starts** school at nine o'clock.
- 5 Daniel **like** / **likes** math and computer science.
- 6 They **do** / **does** their homework in the evening.

### 2 Look at the chart. Fill in the blanks with the words below.

do finishes has have starts **walks**

<b>get up:</b>	6:30		6:30	
<b>breakfast:</b>	7:00		7:00	
<b>go to school:</b>	walk 7:30		walk 8:30	
<b>school:</b>	8:00–3:30 (lunch 12:00)		9:00–3:00 (lunch 12:30)	
<b>after school:</b>	computer games		TV	
<b>dinner:</b>	6:00		6:00	
<b>evening:</b>	homework		homework	
<b>go to bed:</b>	9:30		10:00	
<b>Saturday:</b>	soccer		soccer	
<b>Sunday:</b>	beach		beach	

- 1 Alice **walks** to school at eight thirty.
- 2 Daniel \_\_\_\_\_ classes at eight o'clock.
- 3 Alice \_\_\_\_\_ lunch at twelve thirty.
- 4 Daniel \_\_\_\_\_ classes at three thirty.
- 5 Alice and Daniel \_\_\_\_\_ dinner at six o'clock in the evening.
- 6 Alice and Daniel \_\_\_\_\_ their homework in the evening.

### 3 Complete the sentences.

- 1 Alice **finishes** classes at three o'clock.
- 2 After school, Alice \_\_\_\_\_ TV.
- 3 Alice \_\_\_\_\_ her homework \_\_\_\_\_ evening.
- 4 After school, Daniel \_\_\_\_\_ computer games.
- 5 Daniel \_\_\_\_\_ at nine thirty.
- 6 On Saturday, they \_\_\_\_\_.
- 7 On Sunday, they \_\_\_\_\_.



## Reading

### 1 Look at the title and the picture. Circle the correct answer to the questions.

- 1 This text is about a    a boy.    **b** girl.    3 She is aged    a 13–14.    b 9–10.  
 2 She lives in    a the country.    b the city.    4 She's from    a the U.S.    b Canada.



## Cody Kane's Canadian Village Life

Cody is fourteen and lives in a very small village on a mountain in Canada. She lives with her parents, her brother, and her grandmother. She works on a farm early in the morning. She gets up at 5:30 and has breakfast at 6:00. She finishes work at 9:30 in the morning.

Cody doesn't go to school. On Mondays and Thursdays, the teacher comes to Cody's house. She studies math and science in the morning. Then she has lunch with her teacher. In the afternoon, she studies art and music. On Tuesdays, Wednesdays, and Fridays, Cody takes classes on the Internet. She studies English, geography, computer science, and history on the Internet.

On the weekends, Cody walks, rides her bike, and plays games.

### 2 Read the article. Circle the correct option.

- 1 Cody goes to school / **work** on a farm.  
 2 She gets up / has breakfast at 6:00.  
 3 On Mondays and Wednesdays / Thursdays the teacher comes to Cody's house.  
 4 Cody has some lessons on the Internet / TV.

### 3 Fill in the blanks with the words below.

fourteen    Internet    morning    village    weekends    work

- 1 Cody is **fourteen** .....  
 2 She lives in a small .....  
 3 She finishes ..... at nine thirty.  
 4 She studies math in the .....  
 5 She studies history on the .....  
 6 Cody rides her bike on the .....

### 4 Are the sentences T (true) or F (false)? Correct the false sentences.

- 1 Cody lives with her parents, her sister, and her grandfather.  
 T / **F** Cody lives with her parents, her brother, and her grandmother .....  
 2 Cody goes to bed at five thirty in the morning.  
 T / F .....  
 3 Cody finishes work at nine thirty.  
 T / F .....  
 4 Cody has lunch with her friends.  
 T / F .....  
 5 In the afternoon, Cody does her homework.  
 T / F .....  
 6 On the weekends, Cody walks, rides her bike, and plays games.  
 T / F .....



## 7

## This is me

## Grammar reference

## Simple present (negative)

Affirmative	Negative
I <b>love</b> chocolate.	I <b>don't love</b> chocolate.
You <b>speak</b> English.	You <b>don't speak</b> English.
He / She / It <b>eats</b> hamburgers.	He / She / It <b>doesn't eat</b> hamburgers.
We <b>read</b> magazines.	We <b>don't read</b> magazines.
You <b>listen</b> to music.	You <b>don't listen</b> to music.
They <b>wear</b> T-shirts.	They <b>don't wear</b> T-shirts.

We form the simple present (negative) with *don't* or *doesn't*.

We *don't* start classes at seven o'clock.

He *doesn't* surf on the weekends.

In the negative, *don't* add *-s* / *-es* after *he / she / it*.

She *doesn't* know. (NOT *She doesn't knows*.)

## Simple present (yes / no questions)

Questions	Short answers
<b>Do</b> I <b>wear</b> jeans?	Yes, I <b>do</b> . / No, I <b>don't</b> .
<b>Do</b> you <b>love</b> music?	Yes, you <b>do</b> . / No, you <b>don't</b> .
<b>Does</b> he / she / it <b>eat</b> meat?	Yes, he / she / it <b>does</b> . / No, he / she / it <b>doesn't</b> .
<b>Do</b> we <b>read</b> books?	Yes, we <b>do</b> . / No, we <b>don't</b> .
<b>Do</b> you <b>speak</b> Japanese?	Yes, you <b>do</b> . / No, you <b>don't</b> .
<b>Do</b> they <b>watch</b> movies?	Yes, they <b>do</b> . / No, they <b>don't</b> .

We form questions with *do / does* + subject + verb.

Does he know Nick? Yes, he *does*. / No, he *doesn't*.

## Word list

## Preferences

eat  
hate  
like  
listen  
live  
love  
read  
speak  
wear

## Clothes

cap  
jacket  
jeans  
shorts  
sneakers  
sweatpants  
sweatshirt  
T-shirt



## 7

## Vocabulary

## 1 Match the words with the pictures.

1 love b      2 like \_\_\_\_\_      3 don't like \_\_\_\_\_      4 hate \_\_\_\_\_

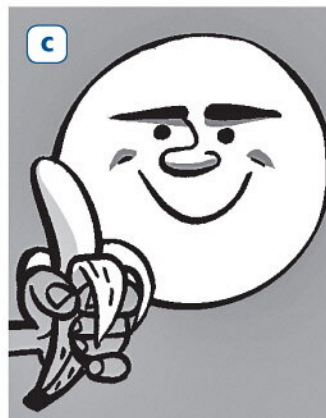
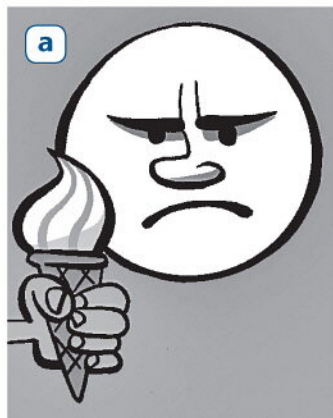

## 2 Fill in the blanks with the words below.

eat    listen    live    read    speak    wear

- 1 I eat meat.      4 I \_\_\_\_\_ to rock music.  
 2 I \_\_\_\_\_ in New York City.      5 I \_\_\_\_\_ sneakers to school.  
 3 I \_\_\_\_\_ English every day.      6 I \_\_\_\_\_ books on vacation.

## 3 Fill in the blanks with the words below.

collect    enjoy    hang out    practice    send



- 1 I enjoy sports.      2 I \_\_\_\_\_ T-shirts.      3 I \_\_\_\_\_ with friends.



- 4 I \_\_\_\_\_ text messages.      5 I \_\_\_\_\_ the piano.



## Grammar

### 1 Look at the chart. Circle the correct verb form.

- 1 I live / don't live in Buenos Aires.  
2 Lisa likes / doesn't like fish.

- 3 We read / don't read science fiction books.



Luis, Argentina

Lisa, U.S.

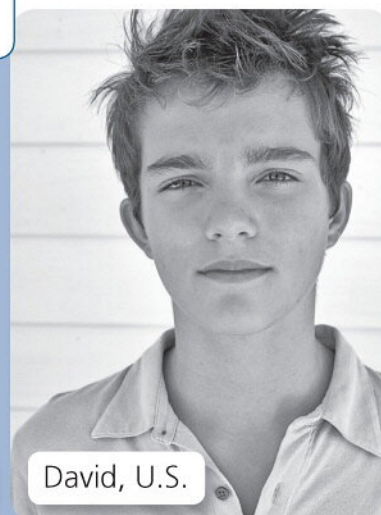

David, U.S.

hometown	Buenos Aires	Boston	Los Angeles
likes (food)	fish	meat	fish
doesn't like (food)	fast food	fish	fast food
reads	music magazines	music magazines	science fiction books
practices	piano	soccer	guitar
speaks	Spanish, English	English, Korean	English, Spanish
listens to	rock music	rock music	rock music

- 4 Luis practices / doesn't practice the guitar.  
5 Lisa speaks / doesn't speak Spanish.  
6 Luis, Lisa, and David like / don't like rock music.

### 2 Fill in the blanks with *don't* or *doesn't*.

- 1 Lisa doesn't live in Los Angeles.      4 Luis and David \_\_\_\_\_ speak Korean.  
2 Luis and David \_\_\_\_\_ like fast food.      5 Lisa and David \_\_\_\_\_ live in Buenos Aires.  
3 David \_\_\_\_\_ practice the piano after school.      6 Lisa \_\_\_\_\_ speak Spanish.

### 3 These sentences are wrong. Write a correct sentence. Use subject pronouns.

- 1 Lisa lives in Los Angeles.  
She doesn't live in Los Angeles. She lives in Boston.
- 2 David likes fast food.  
He \_\_\_\_\_ fish.
- 3 Luis and Lisa read science fiction books.  
They \_\_\_\_\_ music magazines.
- 4 Lisa practices basketball after school.  
\_\_\_\_\_ after school. \_\_\_\_\_ soccer.
- 5 Luis speaks Japanese and French.  
\_\_\_\_\_ Japanese and French. \_\_\_\_\_ Spanish and English.
- 6 Luis, Lisa, and David like classical music.  
\_\_\_\_\_ classical music. \_\_\_\_\_



7

## Vocabulary

### 1 Unscramble the clothes.

- |                            |                    |
|----------------------------|--------------------|
| 1 resneaks <u>sneakers</u> | 5 pac _____        |
| 2 siT-hrt _____            | 6 tackej _____     |
| 3 sneaj _____              | 7 ritweastsh _____ |
| 4 shtros _____             | 8 panweatsts _____ |

### 2 Match the words in exercise 1 with the pictures below.



a 3

b \_\_\_\_\_

c \_\_\_\_\_

d \_\_\_\_\_

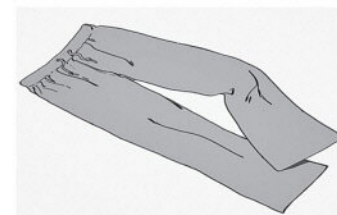

e \_\_\_\_\_

f \_\_\_\_\_

g \_\_\_\_\_

h \_\_\_\_\_

### 3 Label the pictures with the words below.

boots glasses gloves shoes socks sunglasses



1 socks

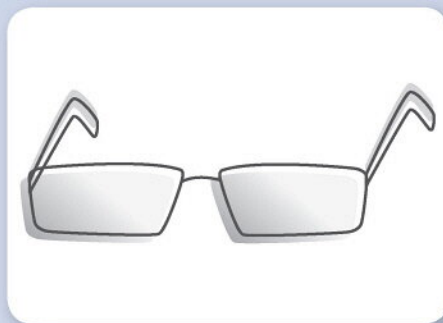

2 \_\_\_\_\_



3 \_\_\_\_\_



4 \_\_\_\_\_



5 \_\_\_\_\_

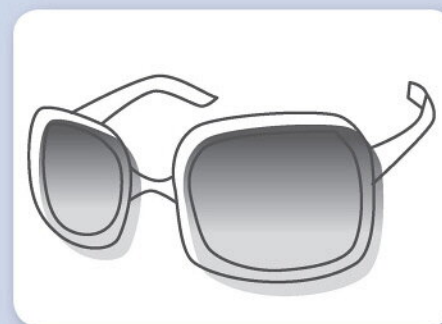

6 \_\_\_\_\_



## Grammar

1 Look at the cards. Match the questions with the answers.

**GABRIELE**



fast food ☹️  
basketball ☹️

**ALFONSO**



hip-hop 😊  
languages: Spanish, English

**MARIANNE**



basketball ☹️  
favorite school clothes: jeans, T-shirt, sneakers

- |   |                    |
|---|--------------------|
| 1 Does Gabriele like fast food?             | a Yes, he does.    |
| 2 Do Alfonso and Gabriele wear glasses?     | b No, she doesn't. |
| 3 Does Alfonso like hip-hop music?          | c Yes, she does.   |
| 4 Does Alfonso speak Italian?               | d No, they don't.  |
| 5 Do Gabriele and Marianne like basketball? | e Yes, they do.    |
| 6 Does Marianne wear sneakers at school?    | f No, he doesn't.  |

2 Fill in the blanks to complete the conversations with *do*, *don't*, *does*, or *doesn't*.

- |  |                   |
|--|-------------------|
| 1 A: <u>Do</u> you wear jeans?             | B: No, I _____.   |
| 2 A: _____ you love music?                 | B: Yes, I _____.  |
| 3 A: _____ he speak French?                | B: Yes, he _____. |
| 4 A: _____ you and your sister read books? | B: No, we _____.  |
| 5 A: _____ it eat meat?                    | B: No, it _____.  |

3 Write questions and answers.

- Mike and Elizabeth / collect T-shirts (no)  
Do Mike and Elizabeth collect T-shirts ? No, they don't
- we / like soccer (yes)  
\_\_\_\_\_ ? \_\_\_\_\_
- she / practice the piano every day (no)  
\_\_\_\_\_ ? \_\_\_\_\_
- they / speak Japanese (yes)  
\_\_\_\_\_ ? \_\_\_\_\_
- he / wear shorts (yes)  
\_\_\_\_\_ ? \_\_\_\_\_
- we / wear sunglasses at school (no)  
\_\_\_\_\_ ? \_\_\_\_\_



## Reading

### 1 Scan the interview. Answer the questions.

- 1 Does Mike Allen listen to music? .....
- 2 Does he play the piano? .....
- 3 Do his sisters like reggae? .....

## ENGAGE interview

Mike Allen, Washington, D.C.

Age: 13



#### Do you listen to music?

Yes, I do. I listen to hip-hop music every day. And I love reggae music. I wear T-shirts with pictures of my favorite bands.

#### Do you play music, too? Guitar? Piano?

No, I don't. But I sing in the shower!

#### Do you have any brothers or sisters?

Yes, I do. I have two sisters. Edith is fifteen and Annie is seventeen.

#### Do they like reggae and hip-hop music?

No, they don't. They like classical music. Edith sings in a choir and Annie plays the piano. She loves Beethoven.

#### Does Annie practice the piano every day?

Yes, she does. After school, she doesn't watch TV and she doesn't hang out with her friends. She practices the piano. And she wears T-shirts with pictures of pianos on them!

### 2 Read the interview. Circle the correct option.

- 1 Mike listens / doesn't listen to classical music.
- 2 He hates / wears T-shirts with pictures.
- 3 His sisters like / don't like classical music.
- 4 Annie hangs out / doesn't hang out with her friends after school.

### 3 Read again. Answer the questions with complete sentences.

- 1 Does Mike live in Washington, DC?  
Yes, he does .....
- 2 Does he hate reggae music?  
.....
- 3 Does Mike play the piano?  
.....
- 4 Do Mike's sisters like hip-hop music?  
.....
- 5 Do Mike's sisters play music?  
.....
- 6 Does Annie wear T-shirts?  
.....

### 4 Complete the short conversations.

- 1 A: Mike doesn't listen to music.  
B: Yes, he does ..... He listens to hip-hop ..... every day.
- 2 A: Mike doesn't like reggae music.  
B: Yes, ..... it!
- 3 A: Mike plays the guitar.  
B: .....
- 4 A: Mike doesn't have any sisters.  
B: .....
- 5 A: Edith is thirteen.  
B: .....
- 6 A: Annie doesn't wear T-shirts with pictures.  
B: ..... of pianos on them.



## 8

## Free time

## Grammar reference

Simple present (*Wh-* questions)

Questions			
What	do	I	sing?
Where	do	you	meet?
When	does	he / she / it	go to the beach?
Why	do	we	like the youth club?
How	do	you	play basketball?
What	do	they	do on the weekends?

We form simple present (*Wh-* questions) with question word + *do / does* + subject + verb.

What does he do on the weekends?

## Expressions of frequency

Questions and answers	
How often do you go swimming?	I <b>never</b> go swimming. We go swimming <b>twice a week</b> .
How often does he / she / it read books?	He reads books <b>once a month</b> . She reads books <b>three times a year</b> .

We form questions with *how often* + *do / does* + subject.

How often does Justin go to parties?

*Never* goes between the subject and the verb.

Justin **never** goes to parties. (NOT Justin goes to parties never.)

Other expressions of frequency go at the end of the sentence.

I go to concerts **twice a year**.

## Word list

## Going out

bowling alley  
concert  
country  
dance school  
party  
skate park  
soccer game  
sports center  
theme park  
youth club

## Leisure activities

exercise  
go online  
go out with friends  
go shopping  
go swimming  
go to the library  
play computer games  
read books  
talk on the phone  
watch TV



## Vocabulary

### 1 Match the words to make places for going out.

- |           |          |
|-----------|----------|
| 1 bowling | a club   |
| 2 soccer  | b alley  |
| 3 skate   | c center |
| 4 sports  | d game   |
| 5 youth   | e park   |

### 2 Find five places in the wordsearch. Then complete the words.

B	Y	C	X	K	F	P	E
J	V	O	I	M	H	A	J
U	L	U	G	K	L	R	N
C	O	N	C	E	R	T	T
I	Z	T	H	E	O	Y	N
P	A	R	K	P	F	G	S
A	C	Y	W	Q	B	D	M
C	S	A	D	A	N	C	E

- 1 c oncert .....
- 2 c .....
- 3 d ..... school
- 4 theme p .....
- 5 p .....

### 3 Fill in the blanks with the words below.

café shopping mall movies restaurant theater zoo

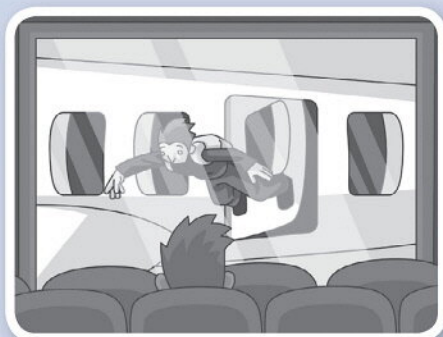

1 He goes to the movies .....



2 He goes to the .....



3 We go to a .....



4 They go to a .....



5 We go to the .....



6 We go to the .....





## Grammar

### 1 Write questions and answers. Use the words in the chart.

When	do you like the skate park?	They go to the movies.
Where	do you go to the café?	She takes the bus.
What	does your mom go to work?	After school.
How	do your parents do on the weekends?	He lives in Miami.
Why	does your uncle live?	Because it's fun!

- 1 When do you go to the café ? After school
- 2 ..... ? .....
- 3 ..... ? .....
- 4 ..... ? .....
- 5 ..... ? .....

### 2 Circle the correct question word.

Vicky: Hi, Matt. (1) Where / When do you live?

Matt: I live on Fourth Avenue.

Vicky: (2) What / When do you start classes?

Matt: I start classes at eight thirty.

Vicky: (3) What / Where do you do after school?

Matt: I do my homework. In the evening, I visit Jaime.

Vicky: (4) When / Where does Jaime live?

Matt: He lives on North Street.

Vicky: (5) How / Why do you visit Jaime?

Matt: Because he's my best friend!



### 3 Write the questions for Vicky.

Vicky: (1) Hi, Anya. Where do you ..... go on Saturdays?

Anya: I go to the sports club.

Vicky: (2) ..... to the sports club? Do you walk?

Anya: No, I don't. I take the bus.

Vicky: (3) ..... do at the sports club?

Anya: I play tennis with my friends.

Vicky: (4) ..... home?

Anya: I go home at twelve thirty.

Vicky: (5) ..... home at 12:30?

Anya: Because I have lunch at home with my family.



# Vocabulary

1 What's another word for free time? Complete the puzzle.

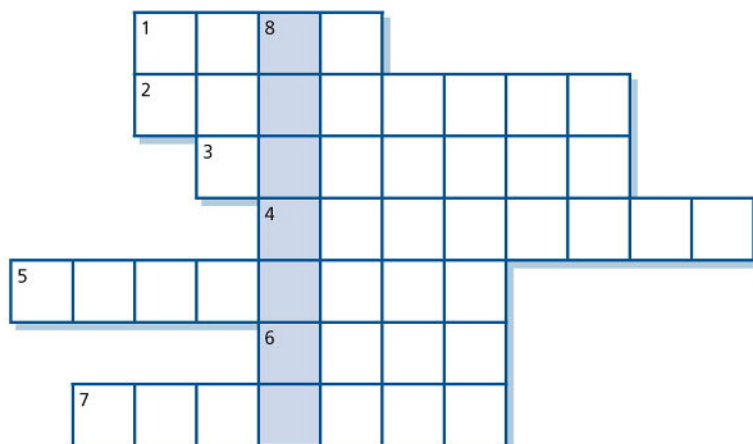

- 1 **talk** ..... on the phone
- 2 ..... at the gym
- 3 go to the .....
- 4 go ..... at the mall
- 5 play ..... games
- 6 ..... books
- 7 go out with .....
- 8 ..... time

2 Match the words to make leisure activities.

- |         |                  |
|---------|------------------|
| 1 go    | a computer games |
| 2 play  | b TV             |
| 3 go    | c online         |
| 4 watch | d swimming       |

3 Match the pictures with the words below.

- 4 chat online    go for a walk    play music    play tennis    watch DVDs





## Grammar

**1** Look at the chart about Pablo and his brother and sister. Circle the correct words in the sentences.

- How often **do / does** Josefina play computer games?  
She **play / plays** computer games every day.
- How often **do / does** Lucas go to the movies?  
He never **go / goes** to the movies.
- How often **do / does** Pablo and Josefina go to the library?  
They **go / goes** to the library twice a year.



swimming	every day	never	every Saturday
movies	twice a week	every Sunday	never
computer games	never	every day	three times a week
library	twice a year	twice a year	once a year
TV	every day	four times a week	every day
concert	four times a year	three times a year	three times a year

**2** Complete the conversation between Pablo and his friend Stan.

Stan: How often (1) do you watch TV?

Pablo: I watch TV three times a week.

Stan: How often (2) \_\_\_\_\_ to the library?

Pablo: I go to the library twice a year.

Stan: How often (3) \_\_\_\_\_ your sister (4) \_\_\_\_\_ swimming?

Pablo: She (5) \_\_\_\_\_ swimming.

Stan: How often (6) \_\_\_\_\_ your brother (7) \_\_\_\_\_ TV?

Pablo: (8) \_\_\_\_\_ TV (9) \_\_\_\_\_.

**3** Write questions and answers.

1 Josefina / movies

How often does Josefina go to the movies ? She goes to the movies once a week

2 Pablo / computer games

\_\_\_\_\_ ? \_\_\_\_\_

3 Josefina and Lucas / concerts

\_\_\_\_\_ ? \_\_\_\_\_

4 Pablo / swimming

\_\_\_\_\_ ? \_\_\_\_\_



## Reading

### 1 Find these words in your dictionary. Write the meaning in your language.

- 1 hot air balloon .....
- 2 festival .....
- 3 controls .....
- 4 weather .....
- 5 skip class .....

### My hot air balloon blog

My name's Jessica and I live in El Paso in the U.S. I'm sixteen years old. My family has a hot air balloon. Every year, there's a balloon festival in El Paso. It's a big party for hot air balloons – for three days! At the festival, we go up in the balloon twice a day – once in the morning and once in the evening.

We go to a balloon festival three times a year because balloon festivals are fun.

My dad can fly a balloon, but I can't. There's a balloon pilot school in El Paso, and on Saturdays, I go to a class. It starts at ten o'clock. We study the balloon's controls and we also learn about the weather. And once a month, we go up in a balloon. It's really interesting. I never skip class!



### 2 Read the blog. Circle the correct option.

- 1 There's a balloon festival in El Paso once / twice a year.
- 2 At the festival, Jessica goes up in a balloon **three** / six times.
- 3 Jessica's family goes to three festivals every year / month.
- 4 Jessica has a balloon pilot class every month / week.

### 3 Fill in the blanks with the words below.

How How What When Where Why

- 1 How ..... old is Jessica?
- 2 ..... does Jessica's family do at the El Paso balloon festival?

- 3 ..... often does Jessica's family go to a balloon festival?
- 4 ..... do they go to balloon festivals?
- 5 ..... is the balloon pilot school?
- 6 ..... does Jessica's class start?

### 4 Write answers to the questions in exercise 3.

- 1 She's sixteen years old .....
- 2 .....
- 3 .....
- 4 .....
- 5 .....
- 6 .....



**OXFORD**  
UNIVERSITY PRESS

Great Clarendon Street, Oxford, OX2 6DP, United Kingdom

Oxford University Press is a department of the University of Oxford. It furthers the University's objective of excellence in research, scholarship, and education by publishing worldwide. Oxford is a registered trade mark of Oxford University Press in the UK and in certain other countries

© Oxford University Press 2014

The moral rights of the author have been asserted

First published in 2014

2018 2017 2016 2015 2014

10 9 8 7 6 5 4 3 2 1

### No unauthorized photocopying

All rights reserved. No part of this publication may be reproduced, stored in a retrieval system, or transmitted, in any form or by any means, without the prior permission in writing of Oxford University Press, or as expressly permitted by law, by licence or under terms agreed with the appropriate reprographics rights organization. Enquiries concerning reproduction outside the scope of the above should be sent to the ELT Rights Department, Oxford University Press, at the address above

You must not circulate this work in any other form and you must impose this same condition on any acquirer

Links to third party websites are provided by Oxford in good faith and for information only. Oxford disclaims any responsibility for the materials contained in any third party website referenced in this work

ISBN: 978 0 19 453869 5

Printed in China

This book is printed on paper from certified and well-managed sources

### ACKNOWLEDGEMENTS

To my parents, Betty and Pedro, for their love, patience and support.

Alicia Artusi

To the memory of my mother, Joanne Carol Fitterer Moore, and to Andrew Fan, for patience and ideas without end.

Gregory J. Manin

*The authors and publishers would like to thank all the teachers and schools whose feedback, comments, and suggestions have contributed to the development of Engage.*

Special acknowledgement is due to Nicki Ludlow for the *I can...* sections.

Cover design by: John Barker

Cover illustrations by: Tim Kahane

Illustrations by: Adrian Barclay pWB28 (ex1); Seb Burnett pp.11, 27 (bedroom), 32 (ex2), 56 (ex1), 90, WB15 (ex1); Mark Draisey pp.16, 17, 51, WB14 (ex3), WB22, WB23, WB34 (ex3); Café Ilustrações 34, 58, 82, 106 (maps), 84, 85; Q2A Media Services PVT. LTD. p.59; Jonathan Edwards pp.80, 104 (ex2), WB11, WB44 (ex1); James Elston pWB39; Andy Hamilton pp.8 (ex 2), 10 (ex5), 25, 27 (ex3), 75; James Hart pp.19 (speaking ex1), 29 (speaking ex1), 43, 53, 67, 77, 91, 101; John Haslam pp.87, WB26 (ex3); Alberto Hoyos pp.32 (ex3), 63, 74 (ex1), 104 (ex3), WB10, WB32, WB33, WB52; Tim Kahane pp.8 (ex1) 19 (flags), 27, 50, 74 (ex2), 81, WB8, WB13, WB16 (ex3), WB29, WB34 (ex2), WB46 (ex3); Joanna Kerr pp.11 (ex1), 33, 56 (ex4), 57 (ex3), 89, WB3, WB5, WB40 (ex2); Estúdio Ilustranet pp.12, 13, 21, 31, 35, 55, 69, 83, 86, 103, 107; Andy Parker 26 (bedroom); Tom Percival pp.40, 41; Andy Peters pp.49, 57 (ex4); Mark Ruffle pp.26 (vocab), 36, 99; Pulsar Studios (c/o Beehive) pp.14, 64, 65, 73, WB15 (ex3), WB17, WB35, WB40 (ex3), WB44 (ex3); Gavin Reece pp.39, 70, 71, 88, WB46 (ex2); Simon Smith pp.29 (bedroom), 55, WB6, WB14 (ex2), WB16 (ex1), WB26 (ex2); Ned Woodman ppWB20, WB38, WB50, WB51

We would also like to thank the following for their permission to reproduce photographs: Alamy Images pp.9 (budgie/Yury Shirokov), 18 (girl eating ice-cream/Anne-Marie Palmer), 23 (small tablet/Martin Shields), 23 (large tablet computer/Oleksiy Maksymenko Photography), 24 (modern computer/Hugh Threlfall), 24 (MP4 player/Trevor Chriss), 28 (Atari 2600/Deezee), 28 (old computer/ClassicStock), 34 (art museum/Claude Thibault), 37 (JK Rowling/Jeremy Sutton-Hibbert), 37 (Usain Bolt/PCN Photography), 38 (Lea Michele/Allstar Picture Library), 41 (Shakira/age fotostock), 42 (Wayne Rooney/Presselec), 50 (fast food counter/Alex Segre), 52 (Staples Centre/Martin Thomas Photography), 52 (Malibu Beach/AHowden - USA Stock Photography), 59 (Península Valdés/Jan Baks), 59 (Iguaçu Falls/David Lyons), 60 (Ted Ligety/ZUMA Press, Inc.), 61 (Tom Daley/Daily Mail/Rex), 62 (boy with horse/Inspirestock Inc.), 65 (no swimming sign/Ajotte Collection), 65 (Do not touch sign/Georgios Kollidas), 65 (no running sign/Lynn Hilton), 66 (powerbocking/Keith Morris), 67 (ice skating/Pictorium), 67 (running/David L. Moore), 76 (playing violin/Pere Sanz), 76 (school/brinkstock), 82 (tomb entrance/The Art Archive), 83 (Tutankhamun's antechamber/Eddie Gerald), 83 (ancient chair/Robert Harding Picture Library Ltd), 83 (scarab jewelry/The Print Collector), 83 (Tutankhamun's mummy/Barry Iverson), 94 (rollercoaster/Serge Bogomyako), 95 (skate park/Adam Duckworth), 95 (youth club/Jeff Morgan), 98 (Group of teens/Adrian Sherratt), 98 (girl on laptop/David Davis Photoproductions RF), 106 (Kikuyu woman Kenya/ERIC LAFFORGUE), 106 (geisha in pink kimono/Chris Willson), 106 (geisha with make-up headshot/Chris Willson), 106 (geisha sandals/Travel Pictures), 106 (geisha in blue kimono/Frantisek Staud), 107 (Queen Elizabeth II and Prince Phillip/Presselect), 107 (painter/All Canada Photos), 107 (teen girl with backpack/Vladimir Godnik), 107 (geisha in green kimono/Mikecranephotography.com), 107 (Buddhist monk/Simon Newbury), WB8 (young boy/Ted Foxx), WB8 (Smiling girl/David Crausby), WB18 (iPod Nano/D. Hurst), WB21 (Portrait of young woman/Janine Wiedel Photolibrary), WB27 (mountains/Tom Till), WB27 (sheep/Wildlife), W28 (High school/Arclight), WB28 (fire station/David R. Frazier Photolibrary, Inc.), W28 (Police station/AA World Travel Library), WB30 (Casa Bonita/Michelle Enfield), WB54 (balloons/Chad Ehlers); Alamy Live News p.61 (Svetlana Shkolina/Bruce Chambers/The Orange County Register/ZUMAPRESS.com); Corbis pp.23 (Mobile phone/Randy Faris), 36 (Mariana Nuñez/Robbie Jack), 37 (Neymar Jr./Ira L. Black), 37 (Isabeli Fontana/Fairchild Photo Service/Condé Nast), 42 (John Rooney/Howard C. Smith/isiphotos.com), 45 (Dr. Robert Rey/DiMaio/Retna Ltd.), 48 (Iguacu River/Frans Lanting), 50 (Fox Theatre entrance/Richard Cummins), 60 (Yohan Blake/PCN), 60 (Mao Asada/Paul Mounce), 61 (Luciana Diniz/Carmen Jaspersen/dpa), 61 (Joaquin Cortes/Fernando Alvarado/epa), 62 (girl with surfboard/Ronnie Kaufman), 72 (Smiling teen girl/Sonja Pachozefafa), 82 (king portrait/Bettmann), 83 (small statue/Robert Harding World Imagery), 83 (ancient sandals/Sandro Vannini), 95 (Energetic hikers/Tom Stewart/Surf), 97 (cyclist/Paul Simcock), 98 (Playing video game/Michael A. Keller), 107 (Inuit man/Rob Howard), WB18 (Asian girl/Bloomimage), WB24 (Adele/Tom Wallace/ZUMA Press), WB27 (bears/John E Marriott); Fotoarena pWB24 (Zezé Di Camargo and Luciano/Alvinho Duarte); Getty Images pp.9 (horse/Bob Langrish/Dorling Kindersley), 14 (teenage boy/Thinkstock), 18 (girl with cup/Yasuhide Fumoto/Taxi Japan), 18 (boy with ball/Digital Vision), 19 (boy with headphones/Westend61), 19 (smiling girl/Eri Morita/Taxi), 22 (old computer/Henry Wolf/Hulton Archive), 28 (old cellular phones/Tim Boyle/Bloomberg), 28 (Atari console/Science & Society Picture Library), 28 (old fashioned TV/Photodisc), 37 (Rihanna/Jared Milgrim/Corbis), 41 (runner/Jay Reilly/Aurora), 41 (Real Madrid football players celebrating/Denis Doyle), 41 (Green Day concert/Ralph Notaro), 41 (artist/Gabe Palmer/The Image Bank), 42 (Penelope and Monica Cruz/WireImage), WB36 (skydiver/Brand X Pictures), 46 (capuchin monkey/Photodisc), 50 (clothes shop/Digital Vision), 50 (bookstore/Reza Estakhrian/Taxi), 50 (bus stop/Omar Torres/AFP), 61 (Mick Fanning/Manuel Blondeau/Corbis), 61 (Erika de Souza/Andrew Snook/Icon SMI/Corbis), 61 (Michael Phelps/Adam Stoltman/Corbis), 64 (Girl playing basketball/Thomas Northcut/Riser), 65 (crossing sign/Stuart Mackenzie/Flickr), 66 (freerunner/Cameron Spencer), 68 (friends/Photographer's Choice RF), 92 (girl on bed/Digital Vision), 96 (performance/Hill Street Studios), 98 (Girl watching television/Nick Daly/Iconica), 98 (Teen swimming/DK Stock/David Deas), 98 (Teens in library/Nancy Honey/Photonica), 98 (Boy using mobile phone/Manfred Rutz/Taxi), 100 (fencer/Berggren, Hans), 105 (girls on stairs/Digital Vision), WB8 (portrait of girl/Nacivet/Photographer's Choice), WB8 (two girls/Rachel Weill/Botanica), WB8 (smiling students/Datacraft), WB9 (friends at beach/Photodisc), WB9 (girls walking/Thinkstock Images), WB12 (boy with surfboard/Stockbyte), WB12 (skiers/Justin Baille/Aurora), WB18 (teen girl/PT Images), WB18 (boy outdoors/Comstock Images), WB18 (boy with football/Elea Dumas/Workbook Stock), WB18 (laptop/Photographer's Choice RF), WB21 (smiling man/Andreas Kindler), WB21 (Doctor/Lifesize), WB21 (Chinese boy/Mike Kemp), WB21 (Teenage girl, Cape Town/David Malan), WB24 (Demi Lovato/Andrew H. Walker), WB28 (librarian/Commercial Eye), WB41 (young boy/Jessica Miller/Workbook Stock), WB41 (teenage girl/Purestock), WB45 (teen boy/Photodisc), WB47 (boy with glasses/Blend Images), WB47 (teenage girl portrait/PhotoAlto), WB48 (red haired boy/Matt Carr/Taxi), WB53 (three teenagers/Blend Images), iStockphoto pp.43 (family/Aldo Murillo), WB27 (Colorado river/Ray Roper); Oxford University Press pp.9 (goldfish/Photodisc), 9 (dog/Photodisc), 9 (mouse/Photodisc), 9 (cat/Photodisc), 9 (hamster/Photodisc), 9 (snake/Photodisc), 14 (girl/Corbis), 14 (boy/White), 21 (smiling girl/Image Source), 24 (Teen girl sitting on skateboard/White), 24 (Teenagers using computer/Imageshop), 25 (Teen girl sitting on skateboard/White), 47 (beach/Carl & Ann Purcell), 50 (Salesperson in Sports shop/Fuse), 50 (Portrait of teenage boy/Image Source), 54 (Big Ben with tulips), 62 (piano playing/Radius Images), 64 (American football/Digital Vision), 64 (Tennis player/Moodboard), 64 (Soccer players/Fuse), 64 (Football team/Image Source), 72 (Smiling teen boy/David Buffington/Blend Images), 94 (Birthday party/Comstock), 95 (Friends bowling/Digital Vision), 98 (Playing basketball/Brand X Pictures), 98 (Teen girl reading/Corbis), 98 (Girls shopping/Stockbyte), 101 (friends/OJO Images), WB8 (smiling boy/Digital Vision), WB47 (girl with glasses/Fancy); Photolibrary pp.14 (young girl/Tetra Images), 18 (boys in snow/White), 20 (teen boys/Cultura), 23 (Skateboard/C Squared Studios/White), 24 (boy & girl/White), 24 (skateboard/Corbis), 25 (boy/White), 28 (Vintage television/Corbis), 30 (girl with bag/Blend Images), 44 (family/White), 48 (Iguacu Falls/Superstock), 48 (toucan/White), 50 (internet cafe/White), 50 (toilet signs/White), 53 (students/Image Source), 64 (kicking ball/Brand X Pictures), 65 (crossing sign/Glow Images RF), 67 (girl footballer/Design Pics Inc), 78 (boy with laptop/Image Source), 90 (Fire alarm on brick wall/Fancy), 91 (pep rally/Corbis), 95 (dance class/Blend Images), 102 (girl on phone/OJO Images), WB12 (girl studying/Blend Images), WB12 (boy with watermelon/Glow Images), WB18 (skateboard/White), WB18 (trainers/White), WB21 (smiling man/Radius Images), WB28 (ambulance/White), WB42 (farm girl/Image Source), WB45 (boy & girl on computer/Brand X Pictures); Pulsar Imagens p.83 (Tiradentes monument/Rubens Chaves); Rex Features pp.37 (Sir Magdi Yacoub/ITV), 37 (Takashi Murakami/Sipa Press), 102 (Alex Rodriguez/Sipa Press); Shutterstock.com pp.3 (large tablet computer/Oleksiy Maksymenko Photography), 15 (Harry Styles/Featureflash), 15 (Adriana Lima/Catwalker), 15 (Rafael Nadal/Neale Cousland), 22 (moderncomputer/Igor Klimov), 23 (modern smart phone/JK1991), 31 (boy and girl/SergiyN), 36 (Bob Burnquist/A. Einsiedler), 37 (Sandra Bullock/Steve Vas), 38 (Cristiano Ronaldo/Madridismo.ES), 38 (Emma Watson/Featureflash), 42 (Emblem3/Helga Esteb), 42 (Robert Pattinson/Vipflash), 42 (Mónica and Penélope Cruz/Debbly Wong), 42 (Serena Williams/Neale Cousland), 42 (Will Smith and Jada Pinkett Smith/s\_bukley), 46 (mountain/Fedor Selivanov), 46 (lake/J. Marijs), 47 (bird/Aleksandr Kurganov), 47 (butterfly/Johan Larson), 47 (forest/Carole Castelli), 47 (waterfall/Jiri Foltyn), 47 (river/Janne Hamalainen), 47 (fox/Pim Leijen), 52 (Rodeo Drive/egd), 52 (Hollywood sign/Andrew Zarivny), 58 (girl/Dora Zett), 58 (Great Wall of China/axz700), 58 (Sydney Opera House/Petronilo G. Dangoy Jr.), 58 (Statue of Liberty/jenhom Chen), 58 (Colosseum/Viacheslav Lopatin), 58 (Machu Picchu/Ckchiu), 58 (Taj Mahal/Matej Hudovernik), 59 (Rocky Mountains/Thomas Barrat), 59 (Eurobanks), 59 (Ouro Preto/Ostili), 66 (wakeskier/Gustavo Miguel Fernandes), 66 (whitewater rafting/jongjet303), 77 (student/Odua Images), 82 (desert/Anton Foltin), 82 (jewelry display/Venus Angel), 82 (tomb of Napoleon/Zoran Karapancev), 82 (Michelangelo's David/Istvan Csak), 82 (step pyramid/David Davis), 82 (golden mask/Jose Ignacio Soto), 82 (Nile River/Francisco Caravana), 82 (desert pyramids/Vikau), 83 (Lincoln Memorial/Jorge Salcedo), 83 (Joan of Arc statue/Francisco Javier Gil), 83 (The Great Pyramid/Rahmo), 86 (teenage boy/Sherianne Talon), 94 (sports center/Brad Sauter), 95 (soccer stadium/Natursports), 100 (girl with microphone/Pressmaster), 100 (snowboarder/Maxim Blinkov), 103 (teenage girl/Pil76), 106 (Saudi Arabian man/Michaeljung), 106 (cowboy/JHDT Stock Images LLC), 106 (Indian woman sari/Zsefe), 106 (woman in black kimono/Darrin Henry), 107 (actress on red carpet/Jaguar PS), 107 (African boy and man/Iofoto); The Bridgeman Art Library pp.34 (Portrait of Dr. Gachet/Christie's Images), 34 (Self-Portrait/Musee d'Orsay, Paris, France/Giraudon), 34 (Bedroom in Arles/Musee d'Orsay, Paris, France/Giraudon), 035 (Starry Night/Museum of Modern Art, New York, USA); ZUMAPRESS.com p.41 (Bruno Mars/Nancy Kaszerman).



# engage

Special edition

## Engaging a new generation

**engage Special edition** captures the imagination of a new generation of teenage learners, providing them with fresh and exciting ways to learn and interact.

New for **engage Special edition**:

- ▶ **Updated content** ensures material is current and relevant to students.
- ▶ **Brand-new Magazine sections** improve students' global awareness and critical thinking skills.
- ▶ **Online Practice** for students, with automatic grading, allows teachers to assign and track homework.
- ▶ **Student website** offers fun, real-world content to consolidate what students have learned.
- ▶ **Interactive e-books** provide new ways of accessing materials in class or at home.

**engage Special edition** continues to offer:

- ▶ **Accessible grammar and vocabulary** lessons that make new language points easy to digest.
- ▶ **A fresh, topical approach** that encourages students to engage with the world around them.
- ▶ **Confidence-building tasks** with realistic aims and opportunities for personalization.
- ▶ **Strong reading syllabus** with extra reading material to develop students' comprehension skills.
- ▶ **Supported skills work** that provides students with strategies for effective communication.
- ▶ **Flexible support package** to suit any teaching style, including iTools for projectors and interactive whiteboards, DVDs, and hundreds of printable resources on the Teacher's Resource Multi-ROM.

### For the student

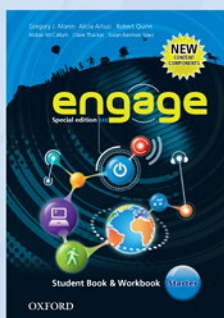

Student Book & Workbook



Online Practice



e-book



Student website  
<https://elt.oup.com/student/engage>

### For the teacher



Teacher's Book



Class audio  
MP3 disc

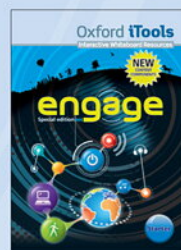

iTools

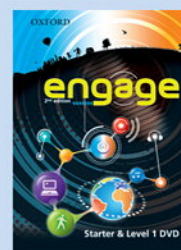

DVD

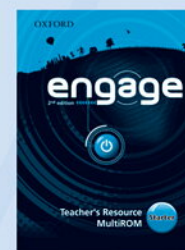

Teacher's  
Resource  
MultiROM

**OXFORD**  
UNIVERSITY PRESS

[www.oup.com.br/elt](http://www.oup.com.br/elt)

SHAPING learning TOGETHER



ISBN 978-0-19-453871-8



9 780194 538718